



# GALVSPAN™

by

## SpandrelTech Ltd.

### GALVANIZED STEEL CURTAIN WALL BACK PANS



**SPECIALIZING IN ARCHITECTURAL PRODUCTS  
FOR THE BUILDING INDUSTRY  
SINCE 1991**

*Featuring Structured Incremental Shipping™  
Catering to the Needs of our Customers*

# GALVSPAN™ GALVANIZED STEEL CURTAIN WALL BACK PANS...

## EXPLANATION

In curtain wall construction the control of heat flow is generally achieved through the use of insulation. Although it is not apparent from the exterior, the curtain wall system uses considerable insulation usually behind spandrel glass or any opaque panels. Because of the materials used in the structure, i.e., glass and metal, which are highly conductive, the system must also contend with potential condensation on the interior surfaces. To curtail this effect, most curtain wall systems incorporate three distinct features: a sealed double glazed window or an insulated metal pan, a thermally broken mullion, and a rainscreen design.

## PRODUCT DESCRIPTION

Galvaspan™ galvanized steel back pans are installed on the interior face of curtain wall systems in spandrel areas and are secured to the wall framing using appropriate fasteners. The cavity of the back pan is filled with mineral wool or fiberglass that is pin welded to the steel pan. Sealing of back pans to mullions is the glazier's responsibility.

Galvaspan™ galvanized steel back pans are available in 20 or 22 gauge galvanized steel, and 4 profiles to suit a variety of conditions. All brake formed back pan corner joints and seams are spot welded, then sealed using a butyl rubber, component sealing compound. The interior side of the pans may be painted as an option for aesthetic reasons i.e. where back pans are visible from the building interior. Painted back pans typically have the insulation secured using self-stick pins.

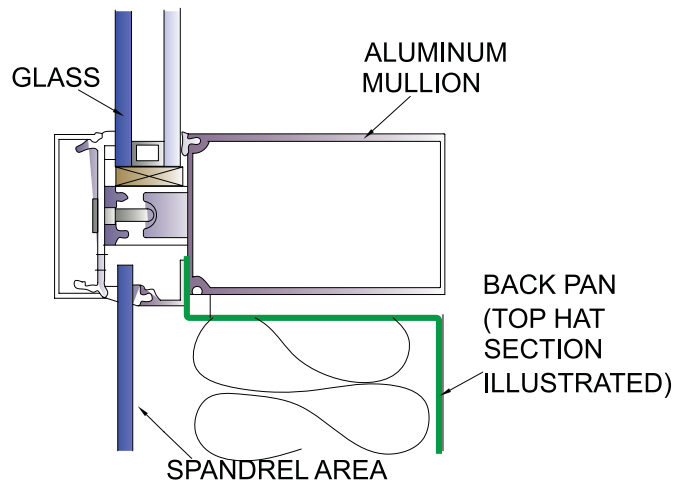

## SECTION THROUGH STANDARD METAL CURTAIN WALL

The profile of Galvaspan™ back pans is dependent upon the sequence of building component installation, how the glass is installed, whether new or retrofit work, and other variables. SpandrelTech Ltd. can advise construction professionals on design.

**Custom Profiles:** Other back pan profiles or shapes can be fabricated. Contact SpandrelTech Ltd. for requirements.

## Standard Back Pan Profiles

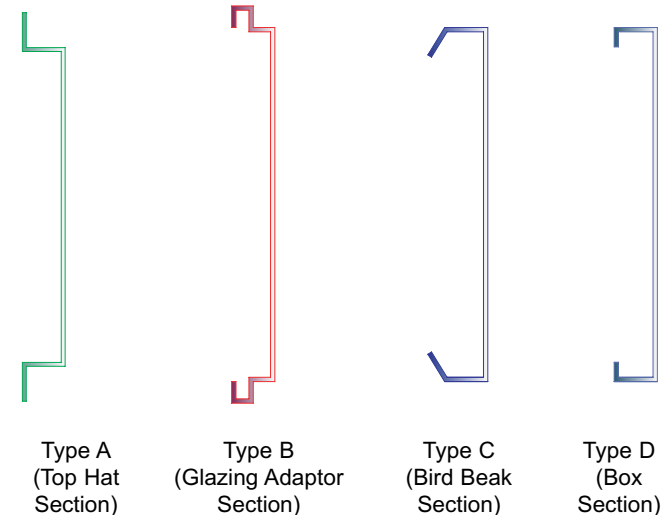

**Dimensional Criteria:** Galvaspan™ back pans custom fabricated to suit project requirements.

**Pan Depth:** Fabricated up to 125 mm (5") thickness in any increment.

**Gauges:** 20 and 22 gauge are standard however pans can be fabricated in any gauge to suit designer's requirements.

**Over Size Pans:** Back pan sizes greater than 2.3 m<sup>2</sup> (25 square feet) are custom fabricated with an integrated joint stiffening design.

**Structured Incremental Shipping™:** If desired, Galvaspan™ back pans may be delivered on a floor-by-floor or elevation-by-elevation basis, for installation convenience.

**Paint Finish (Optional):** If Galvaspan™ back pans are exposed to the interior of the building, the exposed side of the back pan may be painted to meet customer requirements.

## USE

1. On interior face of the curtain wall system in the spandrel area or behind opaque panels.
2. New or retrofit construction.
3. Over steel, concrete, masonry or wood structures.
4. Concealed, or exposed locations (painted backs).

## DESIGN CONSIDERATIONS

Air leakage increases energy costs and reduces occupant comfort in both the winter and summer. The air barrier system used to control air leakage in a curtain wall is usually comprised of glass, metal framing, metal back pans, and the seals that connect all of these components. Care is required in detailing and construction to ensure that the plane of air tightness is continuous. To guarantee performance in a curtain wall system, designers should specify a maximum allowable air leakage rate and the relevant test standard. The Architectural Aluminum Manufacturers Association (AAMA) can provide guidance in this regard.



## For Optimum Energy Conservation - and Interior Appearance



Galvaspan™ back pans (covered with insulation) used in curved wall application. Sundance Plaza, Calgary, Alberta. Manu Chugh Architects.



This facade shows insulation pin welded to back pans prior to being covered with metal wall panels. Alberta Children's Hospital, Calgary, Alberta. Kasian Architecture.

### INSTALLATION

#### Preparatory Work:

Protect steel surfaces in contact with aluminum, concrete, mortar, plaster or other cementitious surface with isolation material or coating such as PVC shims, or alkali resistant bituminous paint.

Touch up building framing members with touch-up primer.

#### Methods:

Back pans to be installed by experienced installers in strict accordance with manufacturer's recommendations and as follows:

1. Provide supplemental steel support members to suit design requirements.
2. Ensure complete and positive nesting of pan edges on wall framing.
3. Install pan square and properly aligned and seal all joints to form an air/vapour seal between pans and structural supports.
4. Secure back pans to wall framing using appropriate fasteners e.g. 25 mm (1") hex-head sheet steel screws and seal screw head with caulking.

Ensure all pan corners and seams are caulked with butyl sealant.

#### Building Codes:

Galvaspan™ back pans conform to building codes.

### AVAILABILITY AND COST

#### Availability:

Distributed across Canada and throughout the U.S.

#### Costs:

Contact SpandrelTech Ltd.

### WARRANTY

One year limited warranty against faulty materials, fabrication or workmanship. Extended warranties available upon request prior to commencement of project. Contact SpandrelTech Ltd. for requirements.

### MAINTENANCE

None required.



This building is equipped with Galvaspan™ back pans behind the aluminum panels. Intercontinental Hotel, Boston. Elkus Manfredi Architects Ltd.

### TECHNICAL SERVICES

1. Preliminary consultation on installation and application.
2. Assistance with shop drawings and expediting projects to successful completion.
3. Technical advice and suggestions for retrofit projects.
4. Accurate estimating for ease of determining final pricing.
5. Consultation with project co-ordinators and site assistance on jobs in progress.
6. Structured Incremental Shipping™.

---

## OTHER SPANDRELTECH PRODUCTS

SpandrelTech Ltd. also manufactures and/or provides the following:

1. Alumaspan™ aluminum wall panels
2. Thermaspan™ custom laminated insulated panels.
3. Porcelain enamel wall panels
4. Formaspan™ metal column covers
5. Steel or aluminum brake shapes, corners and other unique fabricating services
6. Adjustable Z-girts, galvanized or aluminum.

## SPECIFICATION (Short Form)

*Spec Note: See long form 3-Part specification at end of "Galvaspan™ Galvanized Steel Curtain Wall Back Pans" section of manual.*

Curtain wall back pans: "Galvaspan" custom fabricated [20] [22] gauge steel pans [galvanized] [and] [painted\_\_\_colour], sizes as shown on the drawings as manufactured by SpandrelTech Ltd., 16 Erin Park Drive, Erin, Ontario N0B 1T0; Tel: (519) 833-9684 or 1-888-833-9684; Fax: (519) 833-0845; Email: [sales@spandreltech.com](mailto:sales@spandreltech.com); [www.spandreltech.com](http://www.spandreltech.com)

## COMPANY HISTORY

1. Celebrating its 15th anniversary in 2006, SpandrelTech Ltd. continues to thrive and build on its strong reputation for successfully completing innovative curtainwall projects nationwide, and developing extensive relationships with window and siding companies and construction professionals both in Canada and the United States of America.
2. A milestone was marked in 2002 as SpandrelTech Ltd. moved into its new state-of-the-art facility in Erin, Ontario. With the implementation of new CNC equipment throughout the plant, a committed management team, and new, innovative panel design techniques, SpandrelTech Ltd. is changing the face of the urban landscape and remains the proven choice of window and siding companies, architects, and building engineers alike.
3. Complex and unique engineering challenges, complete interior and exterior paneling solutions and Structured Incremental Shipping™ are only a few of the innovative services and products that set SpandrelTech Ltd. apart.



Galvaspan™ back pans are located behind solid panel areas in this outstanding project. Telus Convention Centre, Calgary, Alberta. Graham Edwards Architect.



**SpandrelTech Ltd.**  
16 Erin Park Dr.  
Erin ON N0B 1T0 Canada  
e-mail: [sales@spandreltech.com](mailto:sales@spandreltech.com)

**Tel (519) 833-9684**  
**Toll free 1-888-833-9684**  
**Fax (519) 833-0845**  
**Web: [www.spandreltech.com](http://www.spandreltech.com)**