

Space-Lift™

JUMP FORMING SYSTEM



 **SYMONS**
BY DAYTON SUPERIOR

System Design

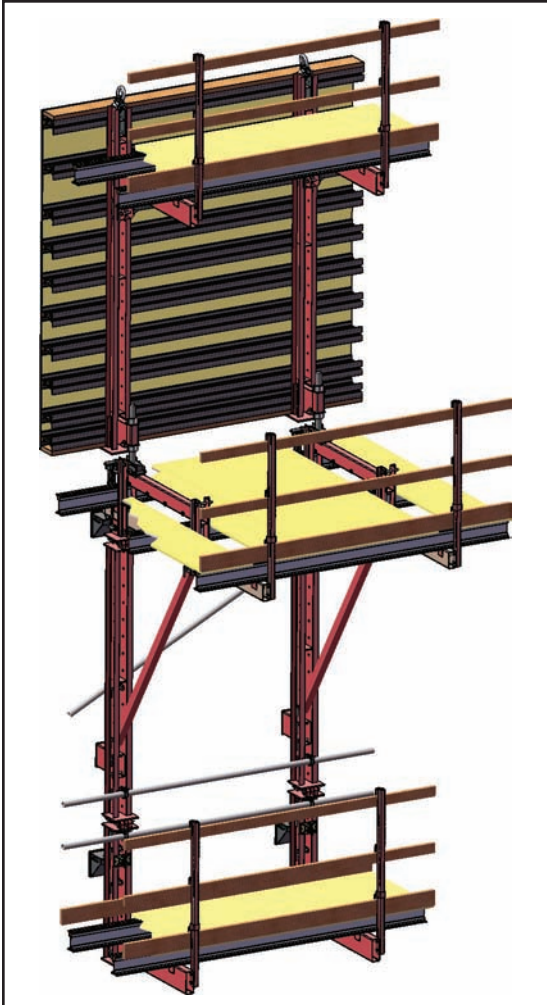

The Space-Lift™ system is a fully-engineered jump form system intended for concrete shear wall applications. The system consists of frame components and a carriage assembly that supports the forming equipment and crew.

The Space-Lift system supports any Symons gang form system that can utilize Versiform® walers, including:

- ◆ Alispoly™
- ◆ Aluminum Beam Gang
- ◆ Flex-Form®
- ◆ FormRight™
- ◆ Steel-Ply®
- ◆ Versiform®

The Space-Lift assembly is suspended from Jump shoes that are bolted to inserts in the concrete wall. The entire assembly remains anchored to the wall during the forming operation. Work platforms provide safe access during setting, placing, stripping and finishing activities. Rollback carriages allow the gang form to be retracted from the wall without being removed. All these activities, of course, proceed without using valuable crane time.

When the gang form is retracted from a completed section of concrete wall, another set of Jump Shoes can be bolted to the inserts in anticipation of the next lift.

Highlights

- ◆ Standard Space-Lift frame heights of up to 16' for higher walls in lobby and atrium areas
- ◆ Space-Lift frame spacing up to 10' o.c. adapts to structure and gang form requirements
- ◆ Rollback form access ranges from 35" with Steel-Ply to 29" with Aluminum Beam Gangs
- ◆ Trailing platform makes operations such as removing Jump Shoes, patching and welding easy and safe
- ◆ The unique Curved Wall Bracket provides angled adjustment for Space-Lift frames on tank applications with a minimum 11' radius.
- ◆ Work platform provides ample room for crews to set, strip and clean forms
- ◆ The assembly is handled as one unit and landed into Jump Shoes, so workers do not need to be on the unit during lifts
- ◆ When properly anchored with Dayton Superior 1" F56 inserts, the Space-Lift system is designed for winds up to 120 mph (193 kph). Tiebacks are required to reduce the effect of wind loads.

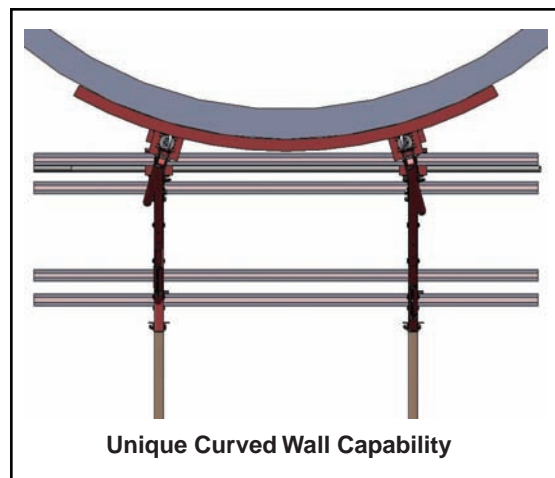
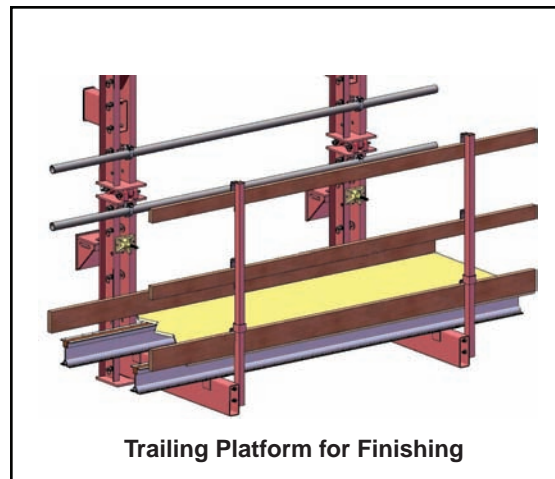
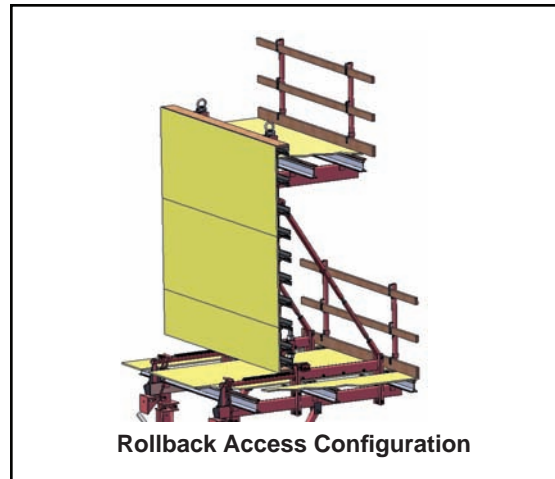

Components



Jump Shoe

Jump Shoes, bolted to inserts anchored in the concrete of the previous pour, support the entire Space-Lift system. The Jump Shoe is designed with a slot to accept a setting pin from the Carriage Assembly. Space-Lift frames can be used on curved walls.

Gang Shear Bracket

Reduces the amount of hardware and assembly time for all of the forming systems used with Space-Lift. Attaching formwork to the Space-Lift frames with fewer pieces means lower material costs, less labor and more production.

Rollback Ratchet Lock

The Ratchet Lock allows the Track Frame to be locked any place along its allowable travel. This provides easy adjustment for locating and positioning the center of gravity when flying the units.

Frame Leg

Frames Legs are 6" steel channels with end plates and gussets. The bottom of the legs have connection studs that bolt to the Carriage Assembly or another Frame Leg.

Carriage Assembly

The Carriage Assembly is an innovative component that allows for as much as 35" of rollback. It includes a tape measure for reference and assembly.

$\frac{3}{4}$ " Diameter Fast Pin

A $\frac{3}{4}$ " diameter Fast Pin (P/C 51396) is used throughout Space-Lift assembly to connect most of the major components. This pin reduces the need for bolted connections, saving time during assembly and construction. The pin has a ball lock which eliminates the need for hair pin clips and the time needed to secure them in place.

Swivel Lift Bracket

The Heavy Duty Swivel Lift Bracket has a 4,000 lb capacity with a 5:1 safety factor to maximize bracket spacing. The swivel mount of the bracket can rotate 360°, and the loop can rotate 180° in a horizontal plane.

Carriage/Waler Bracket

The bracket bolts to the Frame Leg and the 2" screw jack attaches the Carriage Assembly. This provides the vertical adjustment needed to align the inside and outside gangs for tie placement.

Uplift Lock

The Uplift Lock helps prevent the Space-Lift units from disengaging from the Jump Shoe. The Uplift Lock is accessible from the work platform and designed to be easy to check and safely release from this position.

Platform Beams

The work platform is built by connecting Aluminum or H20 Beams to the Access Walkway Bracket and then decking with ¾" plywood (by others).

Work Platform

Final gang form adjustments, plumbing, and Jump Shoe attachment can all be done from the Work Platform. The Work Platform can be used to safely clean the gangs. This operation saves time compared to the conventional method of lowering the gangs to the ground by crane to clean them.

Trailing Platform

Trailing Platforms provide a 30" wide work access to the previously poured concrete wall. This allows a safe platform to patch tie holes, remove Jump Shoes and complete any other necessary finishing work. The Trailing Platform is constructed with aluminum beams or joists and ¾" plywood (by others) for the platform decking.

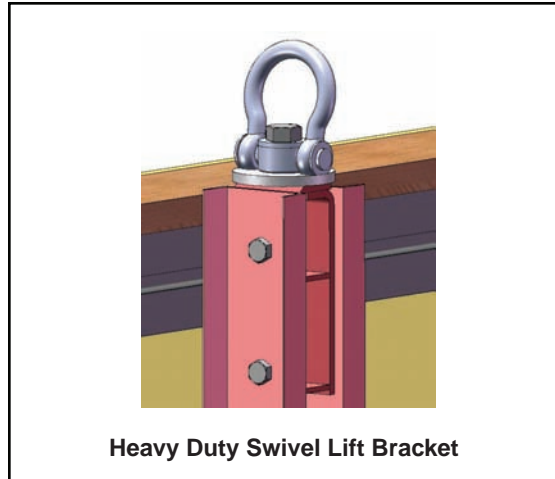

Heavy Duty Swivel Lift Bracket

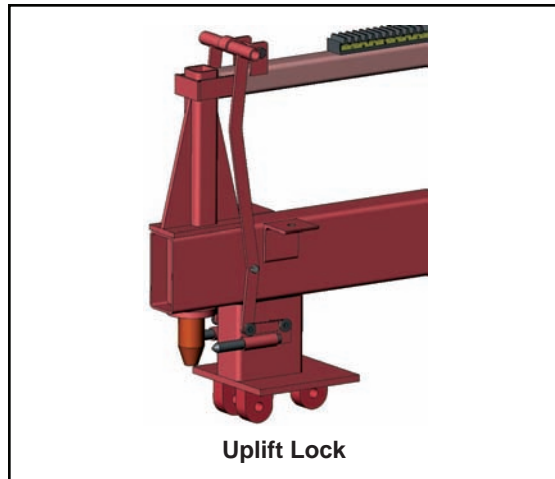

Uplift Lock

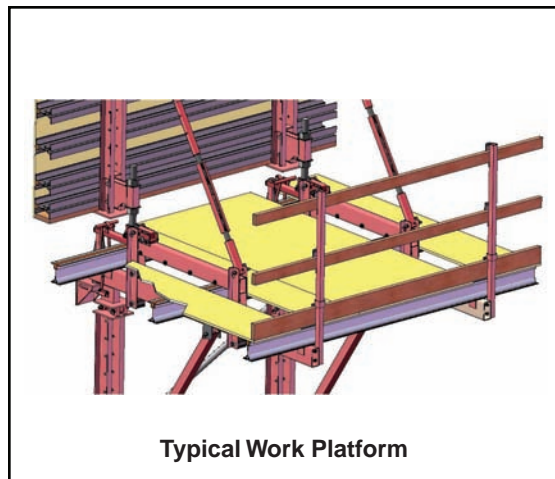

Typical Work Platform

Space Lift™ Assembly



Jump Shoe and Tie Back

Assembly Tools

2" Diameter Gang Form Adjusting Screw — Requires $3\frac{1}{8}$ " open end Carriage/Waler wrench (P/C 51367) or equivalent. A steel wrench made for adjusting screw nuts ($3\frac{1}{8}$ " along flats) stored between channels of any 5" waler or Space-Lift leg.

1" Diameter Carriage Adjustment Nut — Ratchet wrench with at least a 24" long handle and a $1\frac{1}{2}$ " socket or $1\frac{1}{2}$ " box wrench, open end wrench or an equivalent adjustable wrench. 2 are required to simultaneously move a gang form along the Track Frame. (Ratchet wrench recommended)

1" Diameter Anchor Bolt — $1\frac{5}{8}$ " socket or $1\frac{5}{8}$ " box wrench or open end wrench

$\frac{3}{4}$ " Diameter Bolt and Nut — Ratchet wrench with $1\frac{1}{8}$ " socket or $1\frac{1}{8}$ " box wrench or open end wrench or equivalent adjustable wrench.

$\frac{1}{2}$ " Swivel Tube Clamp Nut — Ratchet wrench with $\frac{7}{8}$ " socket or $\frac{7}{8}$ " box wrench, open end wrench or an equivalent adjustable wrench.

$\frac{5}{8}$ " Contour Threaded Bolt and Nut — Ratchet wrench with $1\frac{5}{16}$ " socket or $1\frac{5}{16}$ " box wrench, open end wrench or equivalent adjustable wrench.

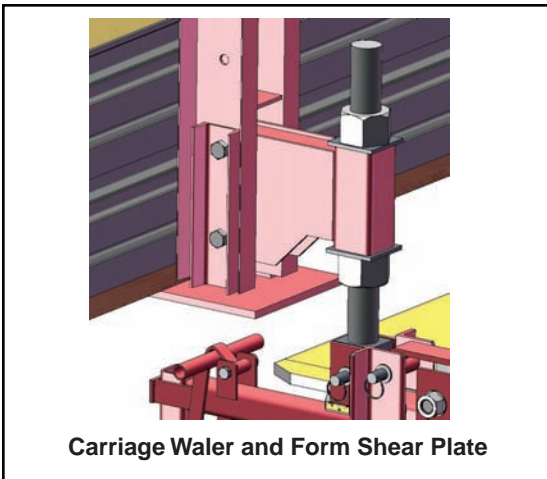

Carriage Waler and Form Shear Plate



Carriage Waler Wrench

Lifting Sequence

Step 1 — Strip and move

Inserts are positioned on the face of the gang form for the Jump Shoes and Space-Lift Frame connections. After the concrete walls are poured and the gang forms retracted, the Jump Shoes are bolted into the inserts for the next lift.

Step 2 — Land and lock

The Space-Lift Frame assembly is lifted into position, lowered onto the Jump Shoe, and quickly secured with the Uplift Lock. The crane can be safely released and the gang form moved by turning the gear assembly with a wrench.

Step 3 — Prep and pour

Inserts are again placed and the forming sequence repeats. Clean the gang forms and apply form release. Move gang form into pour position. Place ties, and pour concrete.

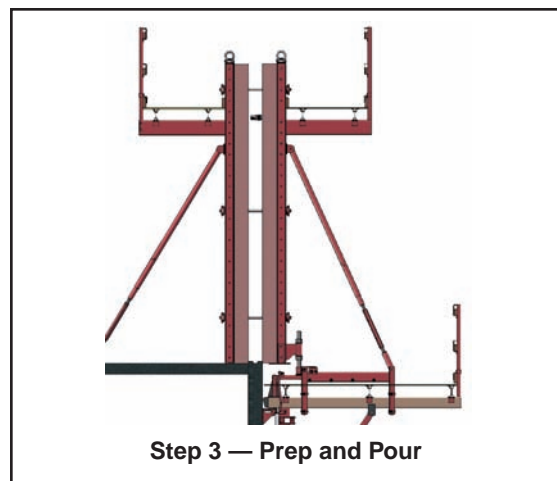
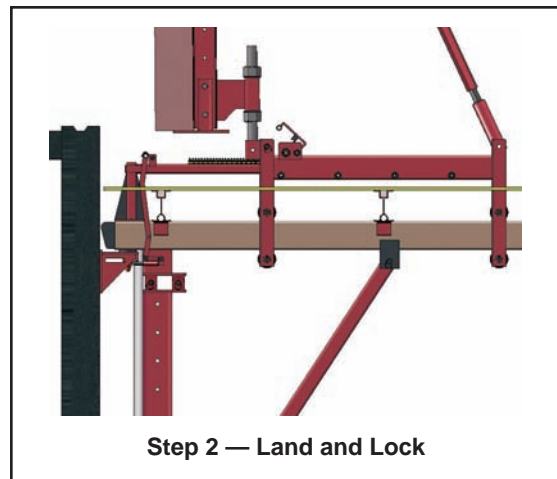
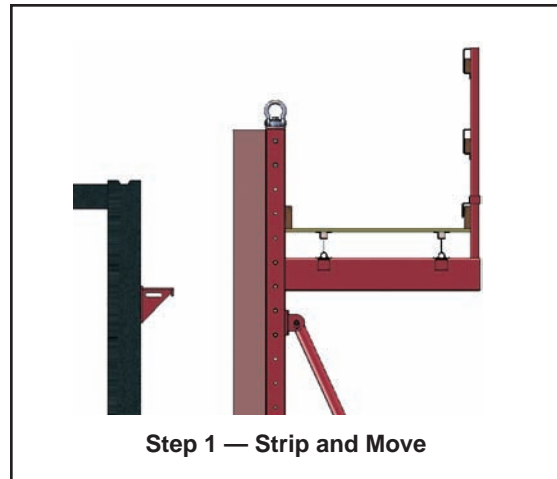



BY DAYTON SUPERIOR

2400 Arthur Avenue
Elk Grove Village, IL 60007 USA
847-298-3200 • FAX 847-635-9287
www.symons.com • info@symons.com

800-800-SYMONS

Adjustable Column Form — Form square or rectangular columns efficiently with a minimum number of steel panels.

Alisply™ — Clamp-type, metric-dimension system is quickly assembled and reconfigured for fast-paced gangforming.

Aluminum Beams and Joists — Lightweight beams/ joists from 4' to 30' (122cm to 914cm) for deck or gangform applications.

Box Culvert Traveler — Rolling steel framework is compatible with Steel-Ply, Versiform and Max-A-Form systems.

Chemicals — Liquid, cement, epoxy and other specialty products for concrete construction and repair.

DeckFast™ — A quick two-component system of modular panels and shores for creating flat concrete decks.

Flex-Form® — Specially designed steel-faced system for forming curved walls and round tanks with no surface “chording”.

Form Liner — More than 100 standard patterns, in four different materials, create unique concrete textures.

FormRight™ — The advantages of a clamp-type gangform, with the handset flexibility for details.

FrameFast™ — Provides 24,000 lb. (106kN) load capacity per shore frame with spacings from 3' to 15' (91.4cm to 457.2cm).

Garage Beam — A complete system to form an economical, poured-in-place concrete parking garage.

Max-A-Form® — A durable, all-steel forming system that is ideal for pier caps and self-spanning applications.

Resi-Ply™ — A low cost, 1½" (2.9cm) plywood forming system for residential construction, in 4-bar, 5-bar and 6-bar spacing.

Roller Deck — Column-mounted deck support system replaces conventional shoring, providing access for other trades.

Room Tunnel — One room per day, per form provides maximum forming productivity for repetitive room designs like hotels.

ShorFast™ — High capacity aluminum leg and jack shoring system can support up to 30 kips (133kN) per leg.

Steel-Ply® — The most recognized modular system, with more than 80 panel and filler sizes, for handsetting or gangforming.

Street Smart™ — Reusable steel forms for residential curb and gutters, industrial slabs and highway paving applications.

Symons Silver™ — A lightweight aluminum system that makes residential forming operations efficient and productive.

Symons Soldier™ — The “next generation” construction beam that can be used as a brace, strongback, waler or shore.

Truss — Crane handling of large aluminum tables increases deck forming productivity for repetitive bays.

Versiform® — Steel frame/plywood face gangforming system that provides a smooth concrete finish.

Printed in U.S.A.
© 2008, Symons
Product Code 91230

