

GlasRoc[®]

High Performance Exterior Sheathing

Featuring Embedded Glass Reinforced Gypsum™



CertainTeed 

Quality made certain. Satisfaction guaranteed.™

CertainTeed respects the environment through the responsible development of sustainable building products and systems.

The building industry continues to look for ways to reduce impact on the environment while meeting customer demand for products that deliver beauty, comfort and performance.

CertainTeed's commitment to these goals is reflected here, highlighting our ongoing effort to become the preeminent supplier of green building materials.



CertainTeed 

A High Performance Exterior Sheathing*

The unique technology behind GlasRoc® Sheathing combines reinforcing glass mats, fully embedded into a water-resistant gypsum core positioned beneath a paperless polymer-modified gypsum surface, and a protective acrylic coating on the exterior face.

GlasRoc® Brand Sheathing offers:

- Long term protection (12 months) to weather exposure.
- A superior water resistant surface that does not inhibit water vapor permeance.
- Excellent fire resistance properties, and numerous fire rated designs.
- Mold resistance.
- Compatibility with most exterior wall systems and applications.

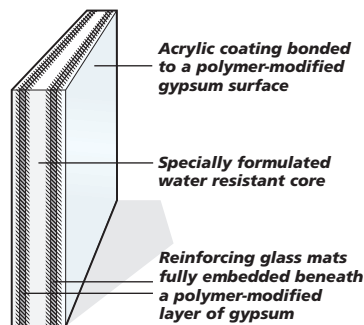

- Conformity to design and code requirements.
- Strength – with enough flexibility to bend to curved surfaces.
- A lightweight sheathing that cuts like regular gypsum board and is easy to handle and install – with minimal skin irritation due to fully embedded glass mats.

GlasRoc® Sheathing is the next generation of the industry standard for high-performance, weather-resistive, gypsum-based sheathing. To back it up, CertainTeed provides a:





- 12 month limited warranty against exposure
- 5 year limited warranty assuring product performance
- 10 year substrate limited warranty in architecturally-specified EIF Systems

* Covered by U.S. Patent No. 6,524,679; 6,878,321; 6,866,492, and other patents pending.

Contents:

Introduction	2
Applications Diagram	3
GlasRoc® Benefits	4
Physical Properties	5
Exterior Wall Systems	6-9
Exterior Designs (Arches/Soffits)	10-11
Fire-Rated Exterior Wall Systems	12-18
Fire-Rated Interior Systems	19-20
Fastening	21
Framing & Joint Treatment	21
Warranty	22
Architectural Specifications	23
Contact Information	24

▼ GlasRoc® Sheathing Fire Resistive Applications:

-  Fire Resistance Rated
Metal Stud Systems
See Pages 12-15
-  Fire Resistance Rated
Wood Stud Systems
See Pages 16-17
-  Fire Resistance Rated
Floor/Ceiling Systems
See Page 18
-  Fire Resistance Rated
Steel Beam & Column
See Page 19

▼ GlasRoc® Sheathing Applications

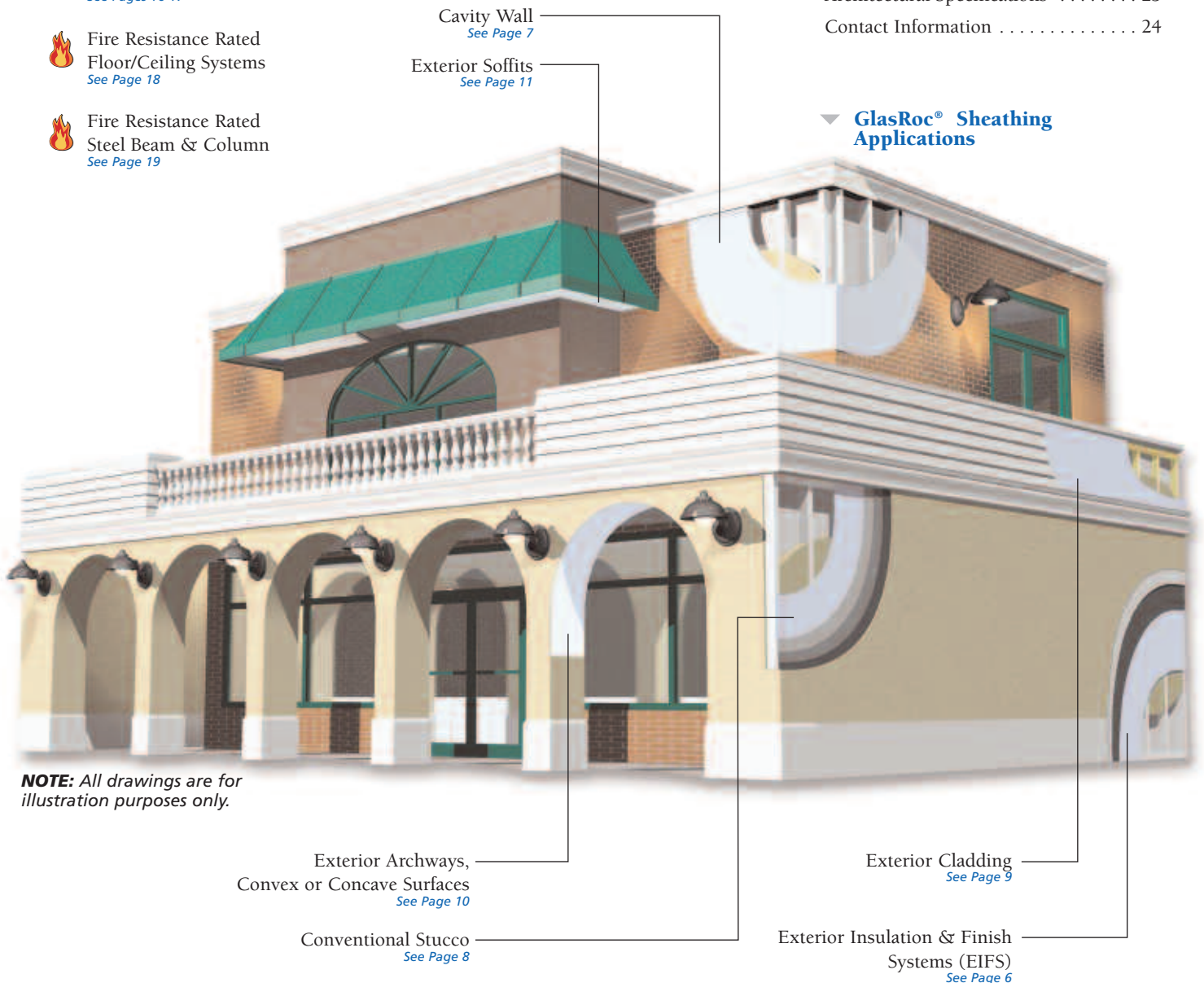

NOTE: All drawings are for illustration purposes only.

Exterior Archways,
Convex or Concave Surfaces
See Page 10

Conventional Stucco
See Page 8

Exterior Cladding
See Page 9

Exterior Insulation & Finish
Systems (EIFS)
See Page 6

GlasRoc® Sheathing

Benefits

Dimensions

Thickness & Type	Width	Length	Edge	Standard
1/2" (12.7 mm) GlasRoc® Sheathing	4'	8' *	Square	ASTM C 1177
5/8" (15.9 mm) GlasRoc® Sheathing Type X	4'	8' *	Square	ASTM C 1177

* Other lengths available. Ask your CertainTeed sales representative.

Better Physical Performance

Tested in accordance with ASTM C 1177, and applicable ASTM C 1396, C 931, and C 79 tests, **GlasRoc®** Sheathing meets or exceeds all physical property requirements. Results showed improved physical performance compared to glass-faced gypsum sheathing including:

- Reduced humidified deflections
- Superior flexural strengths
- Excellent nail-pull resistance

Enhanced Dimensional Stability

GlasRoc® Sheathing will withstand normal exposure to UV, rain, wind, ice, and snow.

It is dimensionally stable under changes in temperature and relative humidity. To back it up, CertainTeed provides a 12 month exposure limited warranty.

Excellent Fire Protection

Testing in accordance with ASTM E 136 proved that **GlasRoc®** Sheathing, with its acrylic coating, is noncombustible and offers superior fire performance compared to paper-faced sheathings. It has a zero flame spread and zero smoke developed index when tested per ASTM E 84 (CAN/ULC-S102) for surface burning characteristics.

GlasRoc® Sheathing Type X is UL and ULC Classified for Fire Resistance for use in fire-rated designs. (UL and ULC Designation - Type EGRG).

Easy to Handle and Install

GlasRoc® Sheathing is handled and installed like regular paper-faced sheathing. In addition, it:

- Can be scored and cut with a standard utility knife. No special tools required.
- Snaps free after scoring only one face.
- Attaches to framing with the same fasteners used for paper-faced gypsum. No special fasteners required.
- Is easier to handle because skin irritations are minimized due to the fully embedded glass mats and our innovative acrylic coating.
- Has uniform field and edge hardness, making trimming & fastening quick and easy.

Long Term Protection to Weather Exposure

GlasRoc® Sheathing, with its homogenous water resistance throughout the board, offers superior freeze/thaw resistance. It will withstand exposure to UV, rain, wind, ice and snow. To back it up, CertainTeed provides a 12 month exposure limited warranty. **GlasRoc®** Sheathing provides enhanced surface liquid water resistance while allowing the building's vapor drive to be unimpeded.

Mold Resistance

Because **GlasRoc®** Sheathing contains no starches or sugars, it will resist mold growth. When tested in accordance with ASTM D 3273, **GlasRoc®** Sheathing exhibited no evidence of mold or fungal growth after a period of 28 days of exposure, yielding a rating of 10.

Increased Durability

GlasRoc® Sheathing resists delamination because the glass mats are fully embedded into the panel, creating a more durable, dimensionally stable panel.

Standards and Code Compliance

GlasRoc® Sheathing conforms to ASTM C 1177, applicable ASTM C 1396/ CAN/CSA-A82.27, C 931, and C 79 standards, and ICC-ES Evaluation Report No. ESR-2460.

Installation standards, where applicable, are Gypsum Association Publication GA-253, GA-216 and ASTM C 1280 for gypsum sheathing and soffits.

- ICC-ES Evaluation Report No. ESR-2460
- NYC MEA 312-03-M
- CCMC Evaluation Listing #13095-L
- Florida Product Approval #FL3029
- Ontario Minister Ruling No: 05-17-141 (13095-R)

Physical Properties

High Performance Sheathing

Properties	Products - 1/2" (12.7 mm)	Products - Fire-Rated 5/8" (15.9 mm)	Test Method/Reference
	GlasRoc® Sheathing	GlasRoc® Sheathing Type X	
Physical Characteristics:			
Nominal Width Inches (mm)	48 (1219)	48 (1219)	-
Weight - Lbs/Square Foot (Kg/m ²)	1.9 (9.3)	2.4 (11.7)	-
Standard Length Feet (mm)	8 * (2438)	8 * (2438)	-
Face Surface	Acrylic/Gypsum	Acrylic/Gypsum	-
Pliability:			
Bending Radius - Dry, Lengthwise, Feet (mm)	4 (1219)	6 (1829)	-
Strength:			
Racking Strength - Ultimate Lbs/Lin.Ft. - (kN/m) Design Value	540 (7.88)	654 (9.54)	ASTM E 72
Parallel Flexural Strength - Lbs. (N)	100 (445)	135 (600)	ASTM C 473
Water Resistance:			
Humidified Deflection (Sag) - Inches (mm)	1/16 (1.6)	1/64 (0.4)	ASTM C 473
Water Vapor Transmission:			
Permeance - perms (ng/Pa•s•m ²)	26 (1500)	21 (1200)	ASTM E 96
Thermal Resistance:			
"R" Value - sq.ft.•h•°F/Btu (K•m ² /W)	0.51 (0.090)	0.51 (0.090)	ASTM C 518
Fire Performance:			
Flame Spread/Smoke Developed	0/0	0/0	ASTM E 84 (CAN/ULC-S102)
Combustibility:	Noncombustible	Noncombustible	ASTM E 136
Dimensional Stability:			
Thermal Coefficient of Linear Expansion - in./in./°F (mm/mm/°C)	9.3 X10 ⁻⁶ (16.7 X10 ⁻⁶)	9.3 X10 ⁻⁶ (16.7 X10 ⁻⁶)	ASTM E 228
Mold Resistance:			
Mold Resistance Rating**	10**	10**	ASTM D 3273

* Other lengths available. Ask your CertainTeed sales representative.

** No mold growth detected. Note 10 is highest rating possible.

GlasRoc® Sheathing

Exterior Wall Systems

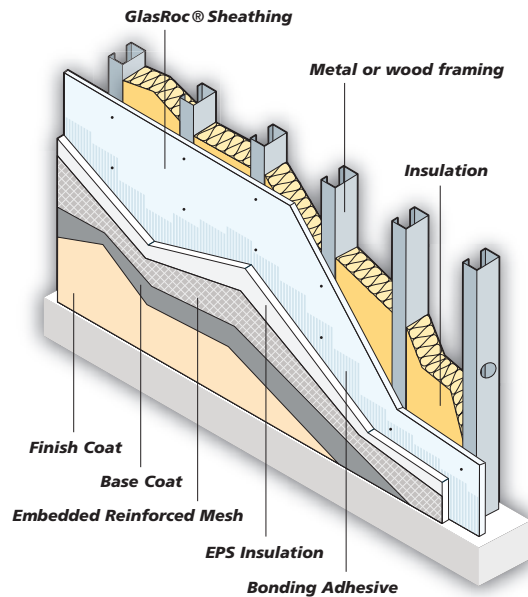

► As a component of an EIF System, GlasRoc® Sheathing offers:

- Superior water shed and surface water resistance.
- Excellent total water absorption resistance.
- Twelve month resistance to UV and environmental exposure.
- Improved insulation adhesion due to integrated board surface.
- Approved substrate by the major EIFS manufacturers.

Exterior Insulation and Finish Systems (EIFS) Applications

Superior Strength

GlasRoc® Sheathing integrally bonds its face coating to the moisture resistant core, resulting in a superior protective sheathing that will perform in all climates.

Dimensional Stability

GlasRoc® Sheathing resists delamination, rippling, buckling and sagging caused by environmental conditions, such as freeze/thaw, heat and humidity, and direct UV exposure. This technology, with its fully embedded glass mats, makes GlasRoc® Sheathing state-of-the-art, and will provide a flat and uniform substrate for EIFS applications.

Moisture Resistance

When properly installed, GlasRoc® Sheathing blocks liquid water without inhibiting water vapor transmission. The result is a protective surface that is extremely resistant to water damage.

Easy to Install

GlasRoc® Sheathing is easier to handle and install. No special tools are required. Score it with a standard utility knife. Install it with standard sheathing fasteners.

Referenced Standards

- ASTM C 514: Specification for Nails for the Application of Gypsum Board
- ASTM C 954: Specification for Steel Drill Screws for the Application of Gypsum Panel Products or Metal Plaster Bases to Steel Studs from 0.33 in. (0.84 mm) to 0.112 in. (2.84 mm) in Thickness
- ASTM C 1002: Standard Specification for Steel Drill Screws for the Application of Gypsum Panel Products or Metal Plaster Bases
- ASTM C 1177: Standard Specification for Glass Mat Gypsum Substrate for Use as Sheathing
- ASTM C 1280: Standard Specification for Application of Gypsum Sheathing
- ASTM C 1397: Practice for Application of Class PB Exterior Insulation and Finish Systems
- ASTM E 84 (CAN/ULC-S102): Test Method for Surface Burning Characteristics of Building Materials
- ASTM E 96: Test Methods for Water Vapor Transmission of Materials
- ASTM E 119/CAN/ULC-S101: Test Method for Fire Tests of Building Construction and Materials



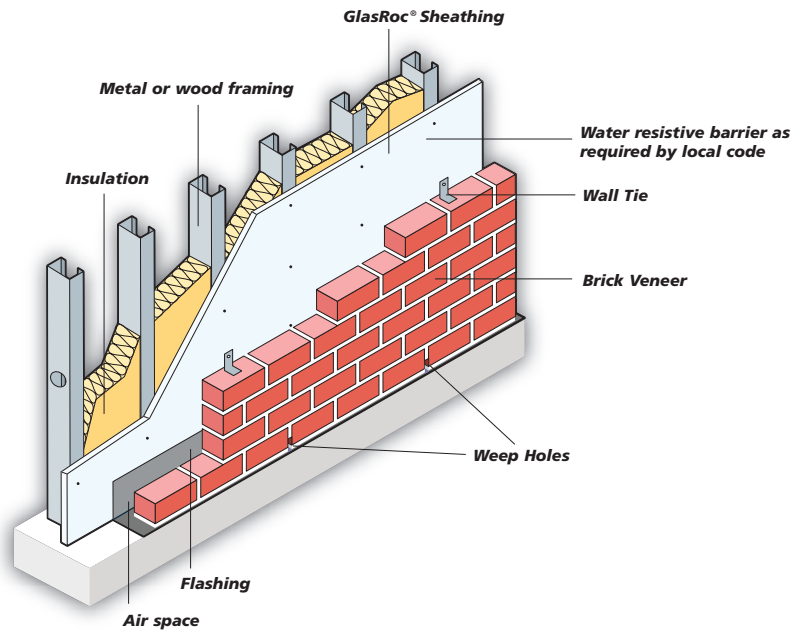

Cavity Wall Applications

GlasRoc® Sheathing offers a protective, smooth, water-resistant application surface which will withstand water penetration into the stud cavity, so a separate weather-resistant barrier may not be necessary, unless required by local code. To best prevent air and water intrusion (when a separate weather resistive barrier is not required by local codes), the joints should be treated with exterior silicone caulk and glass mesh tape. Consult with authority having jurisdiction, prior to installation regarding local requirements.

Installation Recommendations

When installing a brick or stone veneer over GlasRoc® Sheathing, attach the brick or masonry ties through the GlasRoc® Sheathing to the structural framing or supports. Consult the manufacturer or local building code authority for proper spacing and installation of brick or masonry ties.

Referenced Standards

- ASTM C 514: Specification for Nails for the Application of Gypsum Board
- ASTM C 954: Specification for Steel Drill Screws for the Application of Gypsum Panel Products or Metal Plaster Bases to Steel Studs from 0.33 in. (0.84 mm) to 0.112 in. (2.84 mm) in Thickness
- ASTM C 1002: Standard Specification for Steel Drill Screws for the Application of Gypsum Panel Products or Metal Plaster Bases
- ASTM C 1177: Standard Specification for Glass Mat Gypsum Substrate for Use as Sheathing
- ASTM C 1280: Standard Specification for Application of Gypsum Sheathing
- ASTM E 84 (CAN/ULC-S102): Test Method for Surface Burning Characteristics of Building Materials
- ASTM E 96: Test Methods for Water Vapor Transmission of Materials
- ASTM E 119/CAN/ULC-S101: Test Method for Fire Tests of Building Construction and Materials

GlasRoc® Sheathing

Exterior Wall Systems

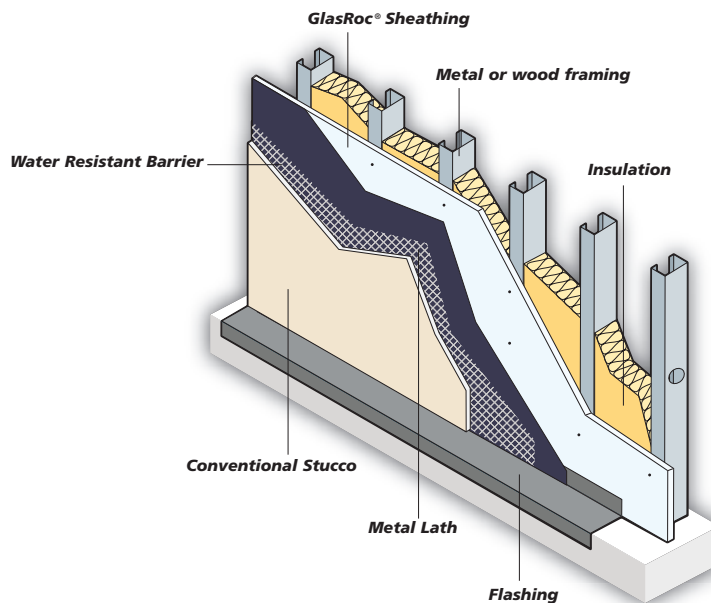

Conventional Stucco Applications

GlasRoc® Sheathing's integral coated surface with its high surface bond strength provides an excellent water-resistant surface for conventional stucco applications. The treated core adds to the water-resistive performance of the product. Conventional stucco systems rely on the structural soundness of the sheathing component to which they are applied. GlasRoc® Sheathing offers physical properties superior to competitive gypsum sheathing products in the market. It is manufactured to meet or exceed the physical property requirements outlined in ASTM C 1177.

Installation Recommendation

In a conventional stucco system, metal lath or other specified self-furring components should be attached to the framing members through the GlasRoc® Sheathing, after the appropriate flashing is installed. Always use appropriate joint treatment when required. Apply the stucco, as recommended by the manufacturer.

Referenced Standards

- ASTM C 514: Specification for Nails for the Application of Gypsum Board
- ASTM C 954: Specification for Steel Drill Screws for the Application of Gypsum Panel Products or Metal Plaster Bases to Steel Studs from 0.33 in. (0.84 mm) to 0.112 in. (2.84 mm) in Thickness
- ASTM C 1002: Standard Specification for Steel Drill Screws for the Application of Gypsum Panel Products or Metal Plaster Bases
- ASTM C 1177: Standard Specification for Glass Mat Gypsum Substrate for Use as Sheathing
- ASTM C 1280: Standard Specification for Application of Gypsum Sheathing
- ASTM E 84 (CAN/ULC-S102): Test Method for Surface Burning Characteristics of Building Materials
- ASTM E 96: Test Methods for Water Vapor Transmission of Materials
- ASTM E 119/CAN/ULC-S101: Test Method for Fire Tests of Building Construction and Materials

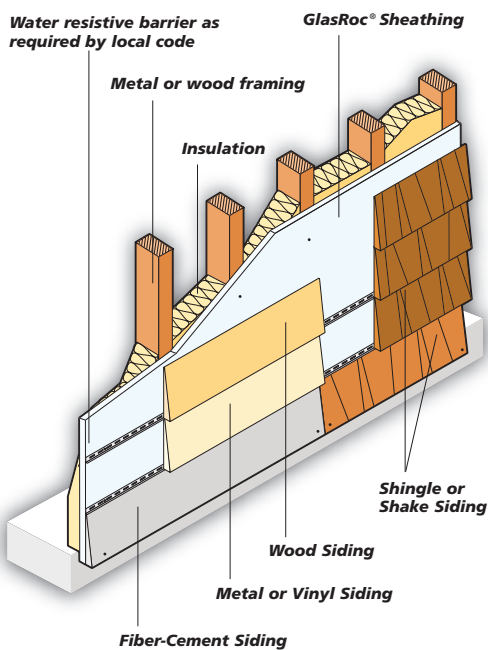

Exterior Cladding

There are numerous exterior claddings available today, from shingles to shakes to a multitude of siding alternatives. GlasRoc® Sheathing is an excellent choice for any of these applications. Simply install GlasRoc® Sheathing and apply the preferred exterior cladding, per the manufacturer's recommendations. Depending on local building codes, a joint treatment, building felt, or building wrap may be necessary.

Referenced Standards

- ASTM C 514: Specification for Nails for the Application of Gypsum Board
- ASTM C 954: Specification for Steel Drill Screws for the Application of Gypsum Panel Products or Metal Plaster Bases to Steel Studs from 0.33 in. (0.84 mm) to 0.112 in. (2.84 mm) in Thickness
- ASTM C 1002: Standard Specification for Steel Drill Screws for the Application of Gypsum Panel Products or Metal Plaster Bases
- ASTM C 1177: Standard Specification for Glass Mat Gypsum Substrate for Use as Sheathing
- ASTM C 1280: Standard Specification for Application of Gypsum Sheathing
- ASTM E 84 (CAN/ULC-S102): Test Method for Surface Burning Characteristics of Building Materials
- ASTM E 96: Test Methods for Water Vapor Transmission of Materials
- ASTM E 119/CAN/ULC-S101: Test Method for Fire Tests of Building Construction and Materials

GlasRoc® Sheathing

Exterior Designs / Arches & Soffits

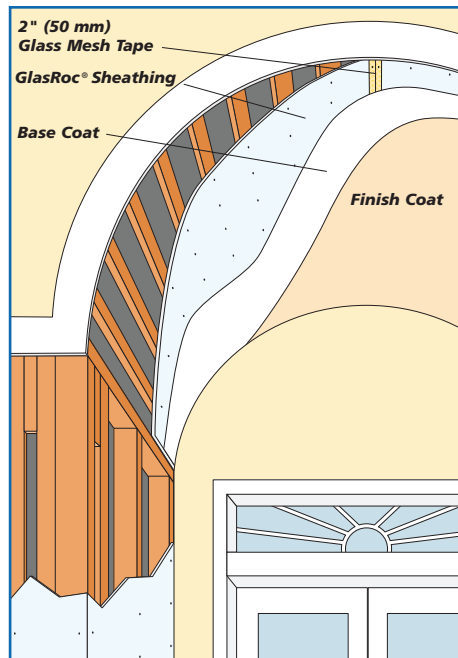

Refer to finish system manufacturer for glass mesh reinforcement requirements.

Recommended Lengthwise Bending Radii

Sheathing Board Thickness	Tested - Bent Lengthwise Radii
1/2" (12.7 mm) GlasRoc® Sheathing	4' - (1219 mm)
5/8" (15.9 mm) GlasRoc® Sheathing Type X	6' - (1829 mm)

Exterior Archways, Exterior Concave & Convex Surfaces

GlasRoc® Sheathing is engineered for use in curved exterior gypsum board applications. There is no need to score or moisten the board to bend it. To prevent flat areas in the curved surface, framing should be positioned at a maximum spacing of 6" (150 mm).

Consult the Gypsum Association document GA-226 for framing recommendations.

Application to Archways

GlasRoc® Sheathing can be installed in an archway or on a concave or convex surface by applying pressure onto the board to fit the radius and then holding it firmly in place while fastening it to the framing members. To best seat the product in tight radius applications, temporarily install a stop at one end of the framed radius to serve as a restraint support. Install the product with coated side out with one of

the width ends placed flush against the temporary stop and secure with fasteners, one framing member at a time. Repeat until the product has been secured to all framing members. Fasteners should be spaced no greater than 8" (200 mm) apart.

Referenced Standards

- ASTM C 954: Specification for Steel Drill Screws for the Application of Gypsum Panel Products or Metal Plaster Bases to Steel Studs from 0.33 in. (0.84 mm) to 0.112 in. (2.84 mm) in Thickness
- ASTM C 1002: Standard Specification for Steel Drill Screws for the Application of Gypsum Panel Products or Metal Plaster Bases
- ASTM C 1177: Standard Specification for Glass Mat Gypsum Substrate for Use as Sheathing

- ASTM C 1280: Standard Specification for Application of Gypsum Sheathing
- ASTM C 1397: Practice for Application of Class PB Exterior Insulation and Finish Systems
- ASTM E 84 (CAN/ULC-S102): Test Method for Surface Burning Characteristics of Building Materials
- ASTM E 96: Test Methods for Water Vapor Transmission of Materials

Exterior Soffit ▼

- ▶ **GlasRoc® Sheathing** is a superior product for a flat ceiling entryway, exterior ceiling, or a soffit assembly, due to its ability to resist deteriorating effects of moisture and humidity.

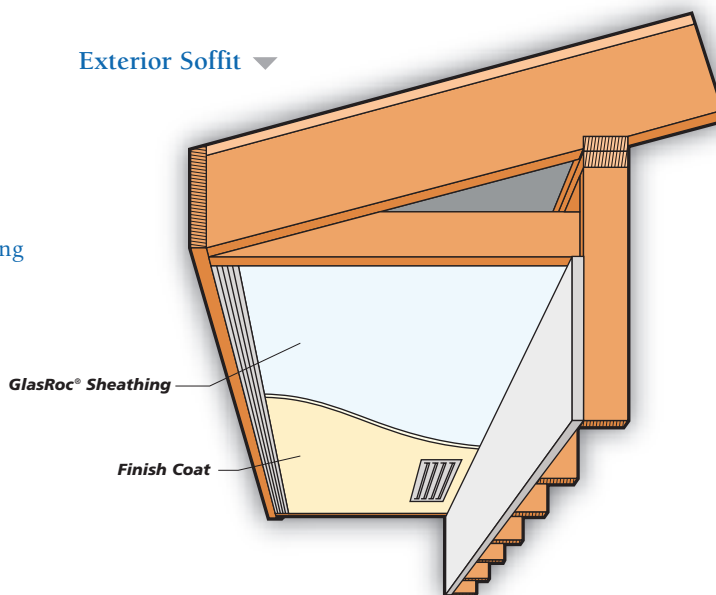

Flat Ceiling Entryways, Exterior Ceilings & Soffits

The industry defines the amount of permissible sagging in a horizontal application as humidified deflection. There are several ASTM Standard Specifications that define a maximum allowable humidified deflection including ASTM C 79, ASTM C 931, ASTM C 1396, and ASTM C 1177. Of these, ASTM C 1177 has the most stringent requirements. Note how **GlasRoc® Sheathing** performs.

Installation Recommendations for Exterior Ceilings & Soffits

Use **GlasRoc® Sheathing** in exterior ceiling and soffit systems where weather-resistant performance is critical, including but not limited to, ceilings/soffits with finished joints and ceilings/soffits without insulation.

Install the product like a standard gypsum exterior soffit board. Fasten the product to the framing members using the recommendations specified in GA-216 and ASTM C 840. Finishing is accomplished with either; 1) Direct - Applied Exterior Finish System (DEFS) per the manufacturer's specifications, or 2) applying 2" x 10 x 10 glass mesh drywall tape and 90 minute setting-type joint compound on the board joints, skim-coating the entire surface of the ceiling/soffit with a setting-type compound and

GlasRoc® Sheathing in Exterior Ceiling & Soffit Applications

Properties	1/2" (12.7 mm) GlasRoc Sheathing	1/2" (12.7 mm) Gypsum Soffit Board	5/8" (15.9 mm) GlasRoc Sheathing Type X	5/8" (15.9 mm) Gypsum Type X Soffit Board	ASTM TEST METHOD
Surface	Acrylic	Paper	Acrylic	Paper	
Humidified Deflection (Sag)	1/16" (1.6 mm)	7/8" (22 mm)	1/64" (0.4 mm)	1/2" (13 mm)	C 473
Water Absorption % by Weight	<10%	40%	<10%	44%	C 473
Surface Water Absorption - grams	<1.6	2.0	<1.6	2.0	C 473

priming and painting with exterior grade primer and paint per the manufacturer's recommendations.

Referenced Standards

- ASTM C 514: Specification for Nails for the Application of Gypsum Board
- ASTM C 931: Standard Specification for Exterior Gypsum Soffit Board
- ASTM C 840: Standard Specification for Application and Finishing of Gypsum Board
- ASTM C 954: Specification for Steel Drill Screws for the Application of Gypsum Panel Products or Metal Plaster Bases to Steel Studs from 0.33 in. (0.84 mm) to 0.112 in. (2.84 mm) in Thickness
- ASTM C 1002: Standard Specification for Steel Drill Screws for the Application of Gypsum Panel Products or Metal Plaster Bases
- ASTM C 1177: Standard Specification for Glass Mat Gypsum Substrate for Use as Sheathing
- ASTM C 1397: Practice for Application of Class PB Exterior Insulation and Finish Systems
- ASTM E 84 (CAN/ULC-S102): Test Method for Surface Burning Characteristics of Building Materials
- ASTM E 96: Test Methods for Water Vapor Transmission of Materials

GlasRoc® Sheathing Type X

Exterior Wall / Fire-Rated Systems

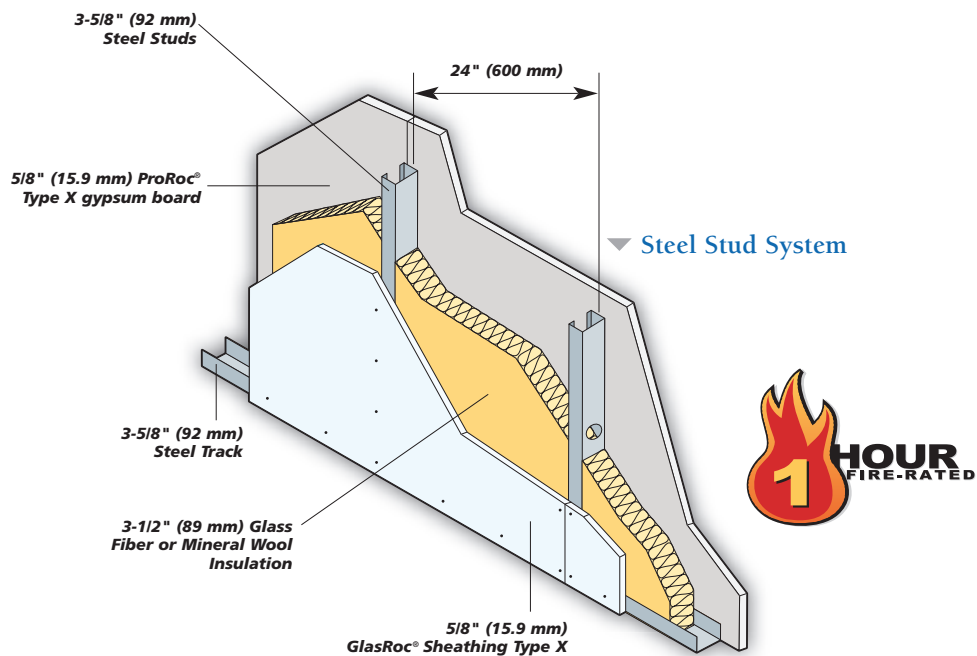

Reference: UL Design U465

1-Hour Fire-Resistance Rating

Cavity thickness 3-5/8" (92 mm)

Wall thickness 4-7/8" (124 mm)

Weight..... 6 psf (29 kg/m²)

Interior

Install insulation between studs. Apply one layer of 5/8" (15.9 mm) ProRoc® Type X gypsum board vertically to interior side with 1" (25 mm) Type S steel screws spaced 8" (200 mm) o.c. along edges, and 12" (300 mm) o.c. in the field. Joints must be offset from joints on the opposite side. Tape and finish joints.

Exterior

Apply one layer of 5/8" (15.9 mm) GlasRoc® Sheathing Type X vertically to exterior side with 1" (25 mm) screws spaced 8" (200 mm) o.c. along edges, and 12" (300 mm) o.c. in the field. Joints must be offset from joints on the opposite side.

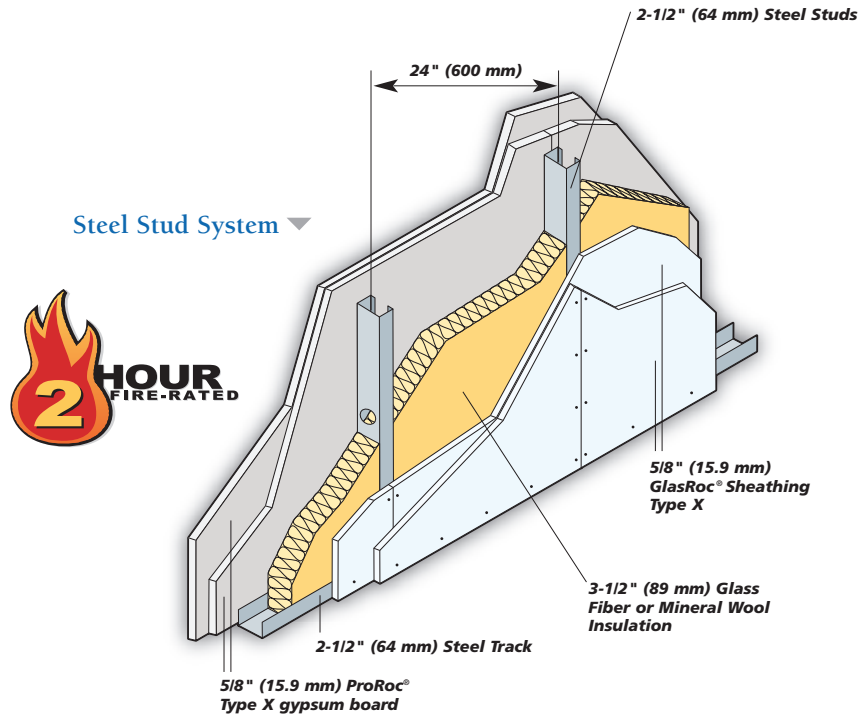

Reference: UL Design U411

2-Hour Fire-Resistance Rating

Cavity thickness 2-1/2" (64 mm)

Wall thickness 5" (127 mm)

Weight..... 11 psf (54 kg/m²)

Interior

Install insulation between studs. Apply a base layer of 5/8" (15.9 mm) ProRoc® Type X gypsum board vertically to interior side with 1" (25 mm) Type S steel screws spaced 16" (400 mm) o.c. along edges and in the field. Joints must be offset from joints on the opposite side.

Apply a face layer of 5/8" (15.9 mm) ProRoc® Type X gypsum board vertically over base layer with 1-5/8" (41 mm) Type S steel screws. Space fasteners 16" (400 mm) o.c. along edges and 12" (300 mm) o.c. along floor and ceiling runners. Joints must be offset from joints in the underlying layer. Tape and finish joints.

Exterior

Apply a base layer of 5/8" (15.9 mm) GlasRoc® Sheathing Type X vertically to exterior side with 1" (25 mm) Type S steel screws spaced 16" (400 mm) o.c. along edges and in the field. Joints must be offset from joints on the opposite side.

Apply a face layer of 5/8" (15.9 mm) GlasRoc® Sheathing Type X vertically over base layer with 1-5/8" (41 mm) Type S steel screws. Space fasteners 16" (400 mm) o.c. along edges and field and 12" (300 mm) o.c. along the floor and ceiling runners. Joints must be offset from joints in the underlying layer.

GlasRoc® Sheathing Type X

Exterior Wall / Fire-Rated Systems

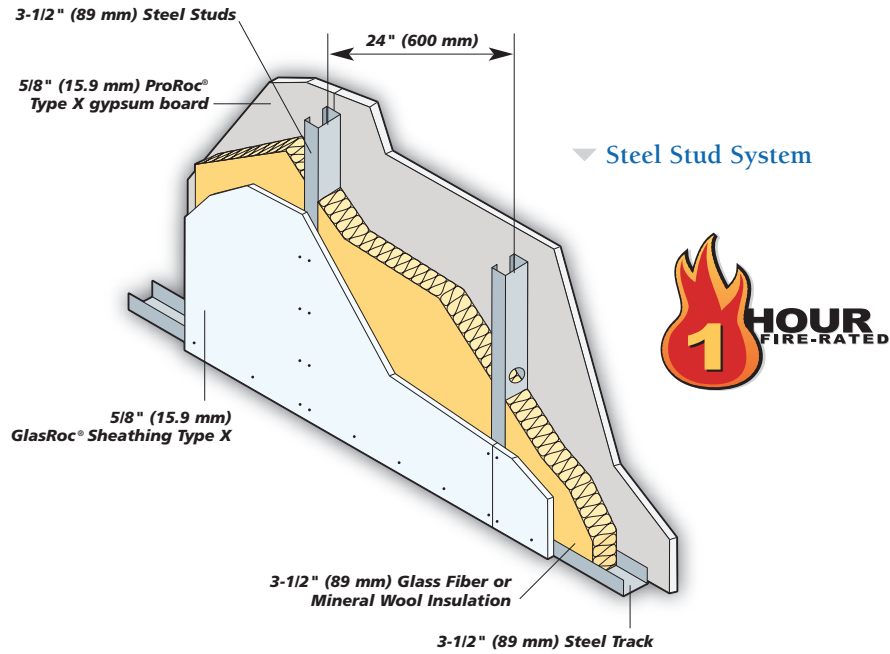

Reference:

UL Design U425

(Load-Bearing)

1-Hour Fire-Resistance Rating

Cavity thickness 3-1/2" (89 mm)

Wall thickness 4-3/4" (121 mm)

Weight..... 6 psf (29 kg/m²)

Interior

Install insulation between studs. Apply one layer of 5/8" (15.9 mm) ProRoc® Type X gypsum board vertically to interior side with 1" (25 mm) Type S-12 steel screws spaced 12" (300 mm) o.c. along edges and in the field. Joints must be offset from joints on the opposite side. Tape and finish joints.

Exterior

Apply one layer of 5/8" (15.9 mm) GlasRoc® Sheathing Type X vertically to exterior side with 1" (25 mm) screws spaced 12" (300 mm) o.c. along edges and in the field. Joints must be offset from joints on the opposite side.

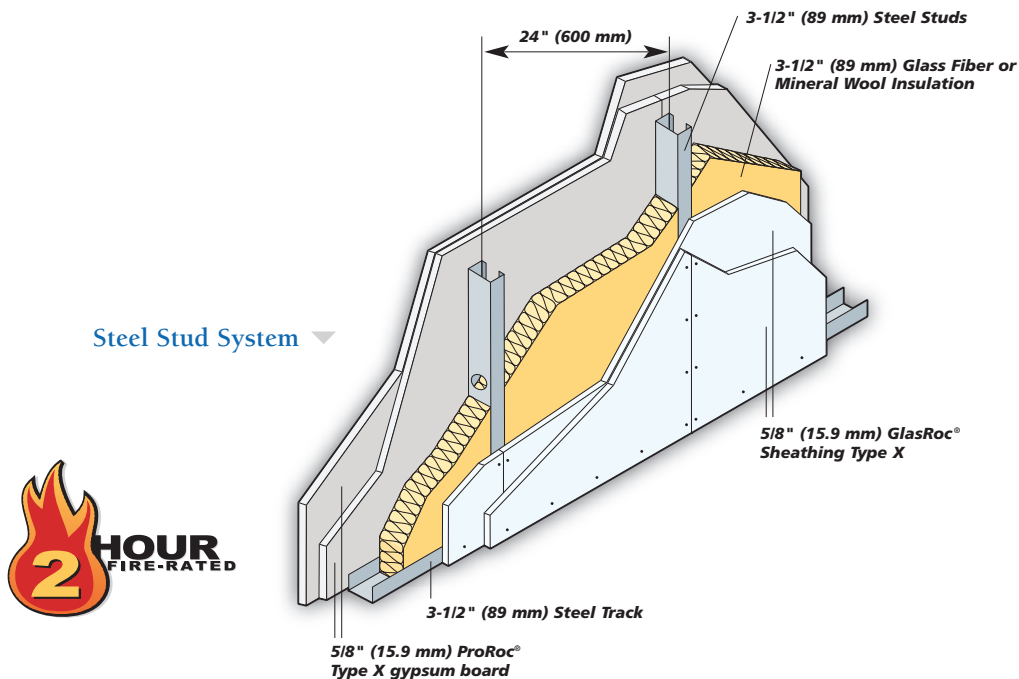

Steel Stud System ▼

Reference: UL Design U425

(Load-Bearing 80% of Design)

2-Hour Fire-Resistance Rating

Cavity thickness 3-1/2" (89 mm)

Wall thickness 6" (150 mm)

Weight..... 11 psf (54 kg/m²)

Interior

Install insulation between studs. Apply one layer of 5/8" (15.9 mm) ProRoc® Type X gypsum board vertically with 1" (25 mm) Type S-12 steel screws spaced 12" (300 mm) o.c. along edges and in the field. Joints must be offset from joints on the opposite side.

Apply a face layer of 5/8" (15.9 mm) ProRoc® Type X gypsum board vertically with 1-5/8" (41 mm) Type S-12 steel screws spaced 12" (300 mm) o.c. along edges and in the field. Joints must be offset from joints in the underlying layer. Tape and finish joints.

Exterior

Apply a base layer of 5/8" (15.9 mm) GlasRoc® Sheathing Type X vertically with 1" (25 mm) Type S-12 steel screws spaced 12" (300 mm) o.c. along edges and in the field. Joints must be offset from joints on the opposite side.

Apply a face layer of 5/8" (15.9 mm) GlasRoc® Sheathing Type X vertically with 1-5/8" (41 mm) Type S-12 steel screws spaced 12" (300 mm) o.c. along edges and in the field. Joints must be offset from joints in the underlying layer.

Additional UL Design Listings for Steel Stud Systems:

U017, U418, U420, U421, U422, U434, U442, U450, U460, U466, U467, U473, U475, U487, U494, U501, U502, U504, U505, U506, U510, U512, U603, U615, U617, U622, U623, U626, U640, V417 and V419.

Additional GA-600 Listings for Steel Stud Systems:

GA File No. WP 7210, WP 9020, WP 9200 and WP 9205.

GlasRoc® Sheathing Type X

Exterior Wall / Fire-Rated Systems

Reference: UL Design U305

1-Hour Fire-Resistance Rating

Cavity thickness 3-1/2" (89 mm)
 Wall thickness 4-3/4" (121 mm)
 Weight..... 7 psf (34 kg/m²)

Interior

Install insulation between studs.
 Apply one layer of 5/8" (15.9 mm) ProRoc® Type X gypsum board vertically or horizontally with 1-7/8" (48 mm) nails spaced 7" (175 mm) o.c. along edges and in the field. Joints must be offset from joints on the opposite side. Tape and finish joints.

Exterior

Apply one layer of 5/8" (15.9 mm) GlasRoc® Sheathing Type X vertically or horizontally with 1-7/8" (48 mm) nails spaced 7" (175 mm) o.c. along edges and in the field. Joints must be offset from joints on the opposite side.

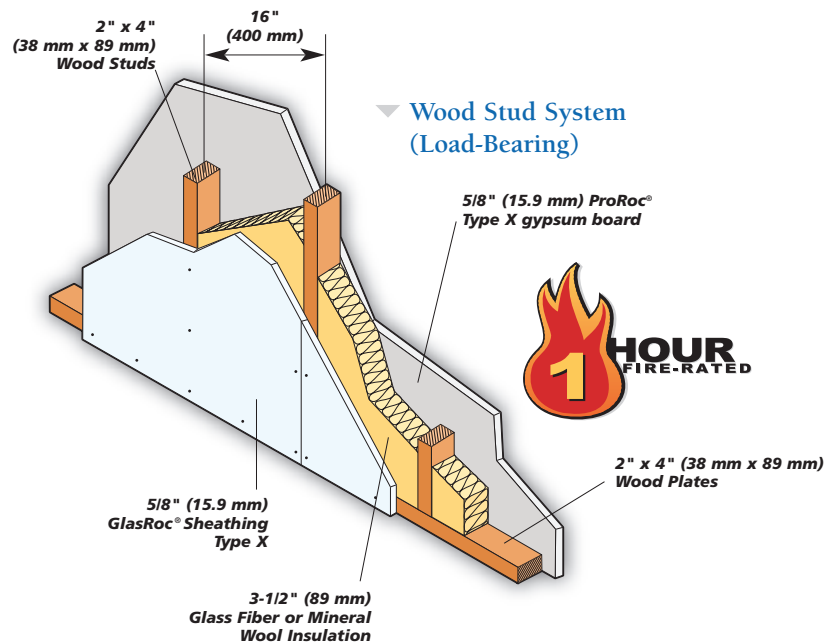

Reference: UL Design U309

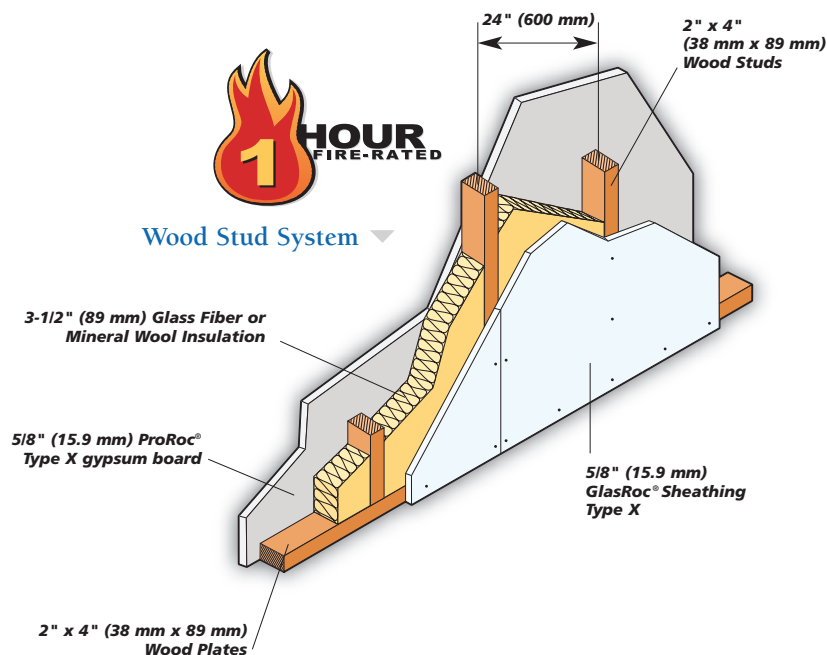

1-Hour Fire-Resistance Rating

Cavity thickness 3-1/2" (89 mm)
 Wall thickness 4-3/4" (121 mm)
 Weight..... 7 psf (34 kg/m²)

Interior

Install insulation between studs. Apply one layer of 5/8" (15.9 mm) ProRoc® Type X gypsum board with 1-7/8" (48 mm) nails spaced 7" (175 mm) o.c. along edges and in the field. Joints must be offset from joints on the opposite side. Tape and finish joints.

Exterior

Apply one layer of 5/8" (15.9 mm) GlasRoc® Sheathing Type X with 1-7/8" (48 mm) nails spaced 7" (175 mm) o.c. along edges and in the field. Joints must be offset from joints on the opposite side.

Reference: UL Design U301

2-Hour Fire-Resistance Rating

Cavity thickness 3-1/2" (89 mm)

Wall thickness 6" (152 mm)

Weight..... 12 psf (59 kg/m²)

Interior

Apply a base layer of 5/8" (15.9 mm) ProRoc® Type X gypsum board vertically or horizontally with 1-7/8" (48 mm) nails spaced 6" (150 mm) o.c. along edges and in the field. Joints must be offset from joints on the opposite side. Vertical joints must be located over framing members.

Apply a face layer of 5/8" (15.9 mm) ProRoc® Type X gypsum board vertically or horizontally with 2-3/8" (60 mm) nails spaced 8" (200 mm) o.c. along edges and in the field. Joints must be offset from joints in the underlying layer. Tape and finish joints.

Exterior

Apply a base layer of 5/8" (15.9 mm) GlasRoc® Sheathing Type X vertically or horizontally with 1-7/8" (48 mm) nails spaced 6" (150 mm) o.c. along edges and in the field. Joints must be offset from joints on the opposite side. Vertical joints must be located over framing members.

Apply a face layer of 5/8" (15.9 mm) GlasRoc® Sheathing Type X vertically or horizontally with 2-3/8" (60 mm) nails spaced 8" (200 mm) o.c. along edges and in the field. Joints must be offset from joints in the underlying layer. Tape and finish joints.

▼ Wood Stud System (Load-Bearing)

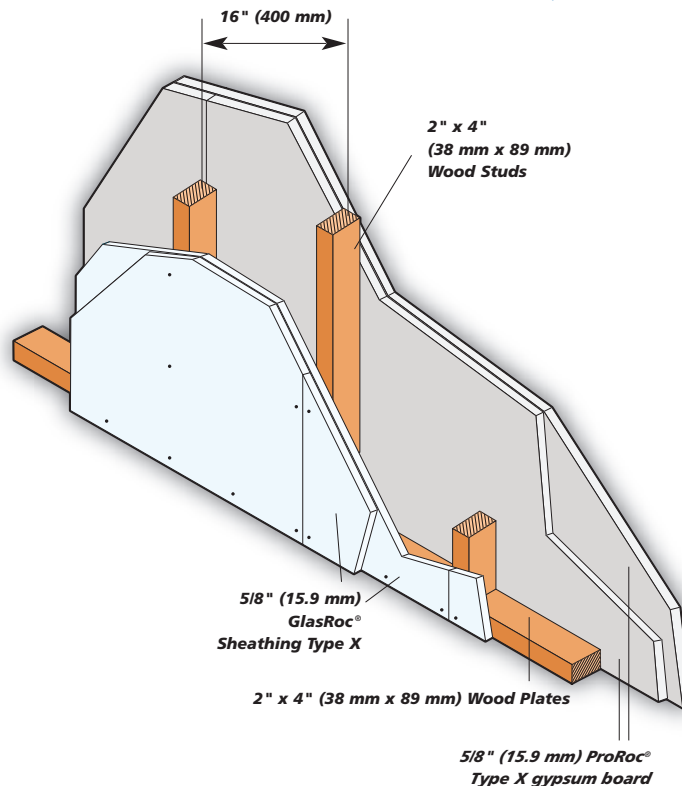

Additional UL Design Listings for Wood Stud Systems:

U326, U329, U330, U332, U337, U338, U339, U341, U342, U354, U355, U357, U358, U360.

Additional GA-600 Listings for Wood Stud Systems:

GA File No. WP 8105, WP 8410, WP 8415 and WP 8420.

GlasRoc® Sheathing Type X

Exterior Wall / Fire-Rated Systems

Reference: UL Design U302

2-Hour Fire-Resistance Rating

Cavity thickness 3-1/2" (89 mm)

Wall thickness 10" (254 mm)

Interior

Install insulation between studs.

Apply a base layer of 5/8" (15.9 mm)

ProRoc® Type X gypsum board vertically or horizontally with 1-7/8" (48 mm) nails spaced 8" (200 mm) o.c. Vertical joints must be located over framing members.

Apply a face layer of 5/8" (15.9 mm)

ProRoc® Type X gypsum board vertically or horizontally to the interior side with 2-3/8" (60 mm) nails spaced 8" (200 mm) o.c. Joints must be offset from joints in the underlying layer. Tape and finish joints.

Exterior

Apply one layer of 1/2" (12.7 mm)

GlasRoc® Sheathing horizontally to the exterior side with 1-3/4" (44 mm) roofing nails spaced 6" (150 mm) o.c. Vertical joints must be located over framing members and staggered.

▼ Wood Stud System

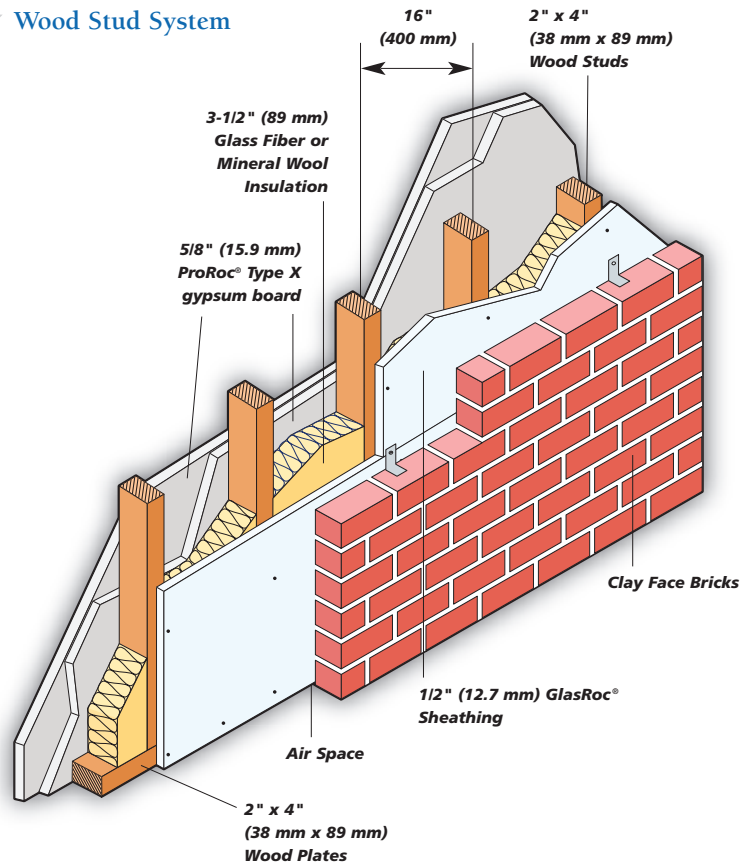

Additional UL Design Listings for Wood Stud Systems:

U326, U329, U330, U332, U337, U338, U339, U341, U342, U354, U355, U357, U358, U360.

Additional GA-600 Listings for Wood Stud Systems:

GA File No. WP 8105, WP 8410, WP 8415 and WP 8420.

GlasRoc® Sheathing Type X

Fire-Rated / Floor & Ceiling Systems

Reference: UL Design G501

1-Hour Fire-Resistance Rating

Flooring

2" (51 mm) 3500 psi (24 MPa) compressive strength normal weight concrete poured over steel deck.

Ceiling

Fasten steel furring channels to joists 24" (600 mm) o.c. with double tie wires, except 12" (300 mm) o.c. at end joints. See Detail A. Adjoining lengths of channels lapped 2'-6" (750 mm).

Apply one layer of 5/8" (15.9 mm) GlasRoc® Sheathing Type X with the long dimension perpendicular to the furring channels with 1" (25 mm) Type S steel screws spaced 12" (300 mm) o.c. Locate screws 1/2" (12.7 mm) from edges and ends of board.

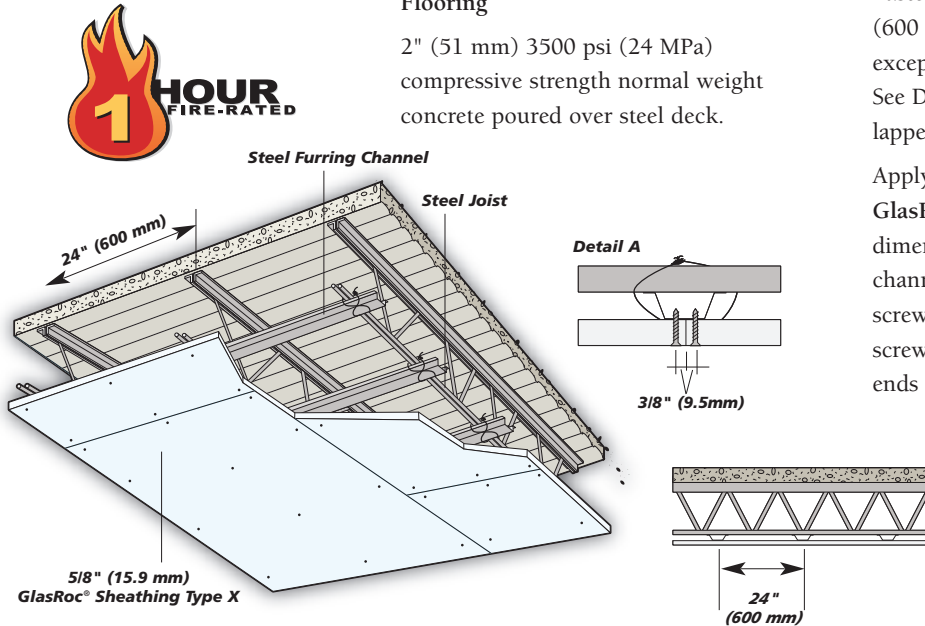

Reference: UL Design L501

1-Hour Fire-Resistance Rating

Thickness 11" (279 mm)

Weight 13.5 psf (66 kg/m²)

Framing

Set joists 16" (400 mm) o.c. Cross-brace and firestop, as required.

Flooring

Apply subflooring with face grain perpendicular to joist with joints staggered. Finished flooring wood structural grade T&G Douglas Fir plywood with face grain perpendicular to joists with joints staggered.

Apply one layer of 5/8" (15.9 mm) GlasRoc® Sheathing Type X with the long dimension perpendicular to joists with 1-7/8" (48 mm) nails spaced 6" (150 mm) o.c. Finish and tape joints.

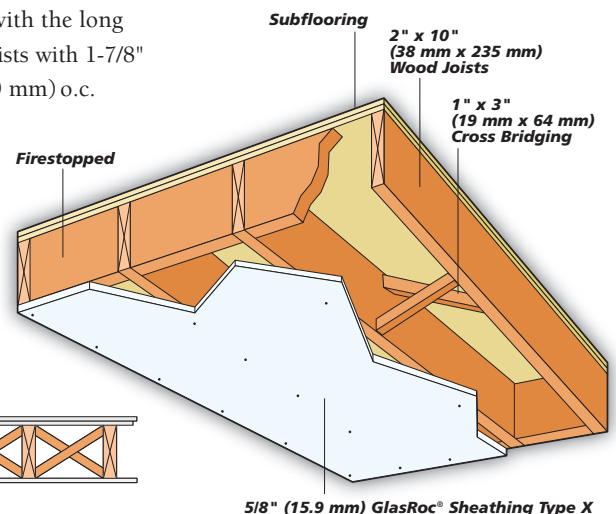
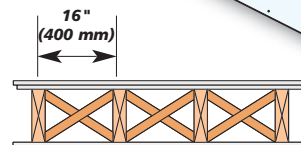

Additional UL Design Listings for Floor-Ceiling Systems

Steel Joist Floor-Ceiling: G520 and G531. Wood Joist Floor-Ceiling: L508, L591.

Additional GA-600 Listings for Floor-Ceiling and Roof-Ceiling Systems

Steel Joist Floor-Ceiling: GA File No. FC 1130, FC 2116, FC 2120, FC 4490 and FC 4750.
Wood Joist Floor/Roof-Ceiling: GA File No. FC 5310, FC 5406, FC 5407, FC 5408, FC 5420, FC 5600, FC 5725, FC 5750, FC 5751, RC 2601, RC 2602, RC 2750 and RC 2751.

GlasRoc® Sheathing Type X

Fire-Rated / Beam & Column Systems

Reference: UL Design N502

2-Hour Fire-Resistance Rating

STEEL BEAM

Attach channels to steel deck with 1/2" (12.7 mm) Phillips pan head screws spaced 12" (300 mm) o.c. Fabricate channel brackets by cutting notches in channel at location of corners and fold channel to form U-bracket of the required size. A minimum 1/2" (12.7 mm) clearance is required at sides and bottom of the beam.

Attach channel to angle 24" (600 mm) o.c., with 1/2" (12.7 mm) Phillips pan head screws. Place steel corner angle at lower corners of U-brackets. Apply a base layer of 5/8" (15.9 mm) GlasRoc® Sheathing Type X

with 1-1/4" (32 mm) Phillips pan head screws spaced 16" (400 mm) o.c. Apply a face layer of 5/8" (15.9 mm) GlasRoc® Sheathing Type X with 1-3/4" (44 mm) Phillips pan head screws spaced 8" (200 mm) o.c. Joints must be offset from the joints in the underlying layer. Attach corner bead to corners. Tape and finish joints.

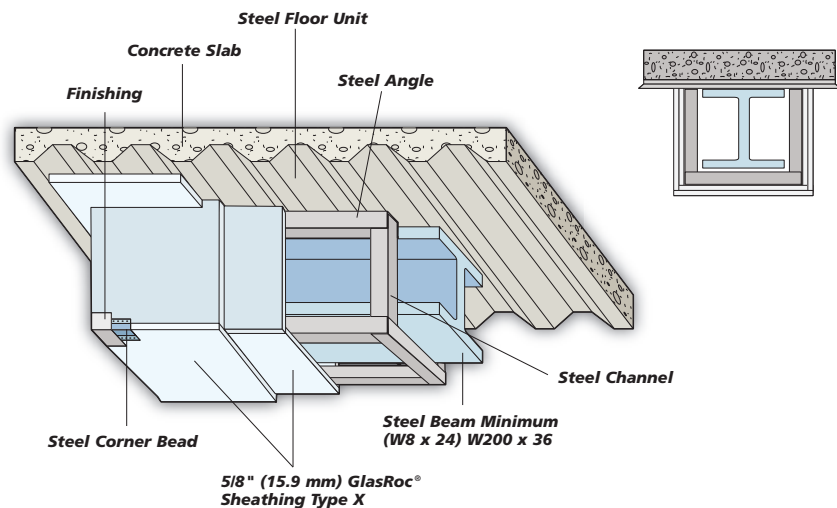

Reference: UL Design X528

2-Hour Fire-Resistance Rating

STEEL COLUMNS

Position steel studs at column corners. Steel studs to be 1/2" (12.7 mm) less than assembly height.

Apply a base layer of 5/8" (15.9 mm) GlasRoc® Sheathing Type X vertically with 1" (25 mm) Phillips pan head screws spaced 24" (600 mm) o.c. Apply a face layer of 5/8" (15.9 mm) GlasRoc® Sheathing Type X vertically around the

perimeter with 1-3/4" (44 mm) Phillips pan head screws spaced 12" (300 mm) o.c. Apply corner bead with 1-5/8" (41 mm) screws spaced 12" (300 mm) o.c. Tape and finish joints.

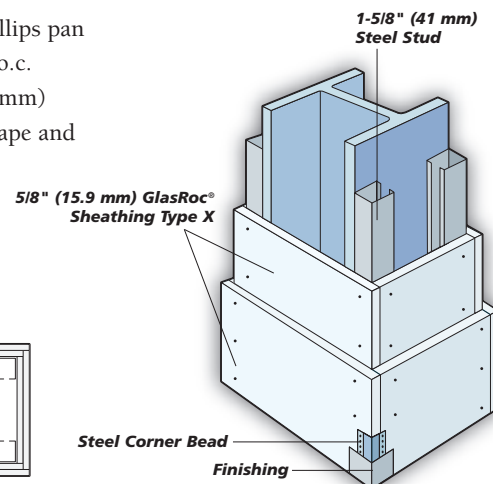
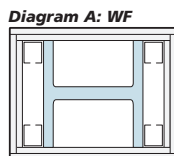

Additional UL Design Listings for Beam & Column Systems

Beam Protection: N501 and N505. Column Protection: X508, X516, X517, X525 and X526.

Additional GA-600 Listings for Beam & Column Systems

Beam Protection: GA File No. BM 2120 and BM 2130. Column Protection: GA File No. CM 1850, CM 1851, CM 2017, CM 2020, CM 2120, CM 3115, CM 3116, CM 3120, CM 3450, CM 3451, CM 4110 and CM 4600.

GlasRoc® Sheathing

Fastening Patterns

Fastening patterns and other detailed information for the recommended handling, storage, and application of gypsum sheathing can be found below and in the following GA installation specification guides: GA-253 Application of Gypsum Sheathing, GA-254 Fire Resistant Gypsum Sheathing, GA-216 Application and Finishing of Gypsum Board, GA-226 Application of Gypsum Board to Curved Surfaces.

Fastening Guidelines

- Fasten GlasRoc® Sheathing using only recommended nails or screws.
- Always apply GlasRoc® Sheathing to a flat and even framing surface.
- Drive fasteners to a point even with or slightly below [no greater than 1/32" (0.8 mm)] the surface of GlasRoc® Sheathing, without penetrating glass mat.
- Locate perimeter fasteners a minimum of 3/8" (10 mm) from edges and ends with a maximum spacing of 8" (200 mm) o.c.
- For shear resistance applications, space perimeter fasteners a maximum 4" (100 mm) o.c.
- Space fasteners in the field of the board a maximum of 8" (200 mm) o.c.

Limitations

- Do not use staples or adhesives to fasten GlasRoc® Sheathing to framing members.
- Do not attach GlasRoc® Sheathing to framing surfaces with a plane variance greater than 1/8" (3 mm).
- Do not overdrive fasteners. Be careful not to break the protective surface coating, fracture the underlying core, or penetrate the glass mat.
- GlasRoc® Sheathing is not recommended or intended for use as a fastening base.
- Not recommended for applications where continuous exposure temperatures exceed 125° F (52° C).

Recommendations for Fasteners

Framing Type	Fastener Description	Recommended Fastener Length for Board Thickness	
		1/2" (12.7 mm) GlasRoc® Sheathing	5/8" (15.9 mm) GlasRoc® Sheathing Type X
Wood	Hot dip 11 gage, 7/16" (11 mm) head, galvanized nail	1-1/2" (38 mm)	1-3/4" (44 mm)
Wood	Hot dip 12 gage, 7/16" (11 mm) head, galvanized nail	1-1/2" (38 mm)	1-3/4" (44 mm)
Wood/Furring	Bugle head (Type W), corrosion resistant screws with coarse threads	1-1/4" (32 mm)	1-1/4" (32 mm) to 1-5/8" (41 mm)
Steel/Furring	Bugle head (Type S), corrosion resistant screws with fine threads	1" (25 mm)	1-1/4" (32 mm)
Light Steel	Bugle head (Type S), corrosion resistant screws with fine threads	1" (25 mm)	1-1/4" (32 mm)
Light Steel	Bugle head (Type S, Type S-12) steel drill screws	1-1/4" (32 mm)	1-1/4" (32 mm) to 1-5/8" (41 mm)
Heavy/Light Steel	Bugle head (Type S-12, Type S) steel drill tip screws	1-1/4" (32 mm)	1-1/4" (32 mm) to 1-5/8" (41 mm)
Heavy Steel	Bugle head (Type S-12) drill tip, fine thread, rust resistant gypsum board screws	1" (25 mm)	1-1/4" (32 mm) to 1-5/8" (41 mm)

Framing & Joint Treatments

Wall Framing

Where required, diagonal let-in bracing is recommended for corners.

- 1/2" (12.7 mm) GlasRoc® Sheathing should be fastened to wood or steel framing spaced no more than a maximum of 24" (600 mm) o.c.
- 5/8" (15.9 mm) GlasRoc® Sheathing Type X should be fastened to wood or steel framing spaced no more than a maximum of 24" (600 mm) o.c.

Ceiling and Soffit Framing

- 1/2" (12.7 mm) GlasRoc® Sheathing should be fastened to wood or steel framing spaced no more than a maximum of 16" (400 mm) o.c. for parallel to stud framing and maximum of 24" (600 mm) o.c. for perpendicular to stud framing.
- 5/8" (15.9 mm) GlasRoc® Sheathing Type X should be fastened to framing spaced no more than a maximum of 24" (600 mm) o.c. parallel or perpendicular to wood or steel framing.

GlasRoc® Sheathing

5 Year Limited Warranty

What is Covered?

5 Year Limited Warranty Against Defects

CertainTeed Gypsum (“CertainTeed”) warrants that its GlasRoc® Sheathing (“Product”) shall be free from defects in the manufacture of materials that make it unsuitable for its intended use, and that it meets or exceeds the manufacturing requirements and specifications of ASTM C 1177.

12 Month Warranty Against Exposure

CertainTeed further warrants for up to twelve (12) months that the Product will withstand exposure to normal weather conditions, e.g., UV, rain, wind, ice and snow, so long as the Product is stored and installed according to CertainTeed’s instructions contained in Sections 1.6 and 3.1 of the GlasRoc® Sheathing Architectural Specifications.

The 5 Year Limited Warranty and the 12 Month Limited Warranty extend to dealers who sell this Product, contractors who install this Product, and the original owner of the building within the warranty period. Neither the 5 Year Limited Warranty nor the 12 Month Limited Warranty may be assigned or transferred.

How Long Does Coverage Last?

The 5 Year Limited Warranty shall commence with the date of purchase by the installing contractor or product applicator, and continue for five (5) years. The 12 Month Limited Warranty shall commence on the date of installation of the Product and continue for twelve (12) months.

What is Not Covered?

CertainTeed shall not be responsible for any loss resulting from any of the following:

- Installation practices not in accordance with CertainTeed’s published recommendation and specifications.
- Improper design or installation of any component or portion of the structure.

- Damage to GlasRoc® Sheathing caused by an EIFS system not installed in accordance with the application instructions of the EIFS manufacturer, the architectural specifications or ASTM C1397, “Standard Practice for Application of Class PB Exterior Insulation and Finish Systems”.
- Moisture intrusion defects including insect, fungus, and mold infestation resulting from the use of other manufacturers’ products.
- Failure of the owner to maintain the building with reasonable care.
- Use of GlasRoc® Sheathing as a substrate for any exterior or coatings that are directly applied to the panel surface (excluding soffit areas).
- Excludes damage caused by improper handling or storage, immersion in water, floods, fires, hailstorms, earthquakes, high winds, hurricanes, acts of nature, falling objects, settling of the building, movement of the framing members, failure or distortion in the walls or foundation of the structure.
- CertainTeed is not responsible for the performance of the exterior system applied over GlasRoc® Sheathing including but not limited to coatings, cladding and wall coverings.

Effect of State/Provincial Law

THIS WARRANTY STATES THE FULL EXTENT OF CERTAINTEED’S RESPONSIBILITY FOR DEFECTS IN THE PRODUCT. ALL OTHER REPRESENTATIONS AND WARRANTIES EITHER EXPRESSED OR IMPLIED, INCLUDING WARRANTIES OF FITNESS FOR A PARTICULAR PURPOSE OR MERCHANTABILITY, ARE HEREBY DISCLAIMED.

IN NO EVENT SHALL CERTAINTEED BE LIABLE FOR LOSS OF PROFITS OR ANY CONSEQUENTIAL, SPECIAL, INCIDENTAL, INDIRECT OR PUNITIVE DAMAGES, WHETHER BASED UPON BREACH OF WARRANTY NEGLIGENCE, STRICT LIABILITY, TORT, BREACH OF CONTRACT, OR ANY OTHER LEGAL THEORY.

Some states do not allow the exclusion or limitation of warranties or do not allow the exclusion or limitation of incidental or consequential damages, so the above disclaimers may not apply to you.

What will CertainTeed do?

CertainTeed will, at its option, provide replacement Product or a refund up to double the purchase price.

How To Handle Claims?

Submit all claims in writing within 30 days of the defect discovery, including a brief description of the damaged area, with a copy of the dated sales receipt, invoice and evidence of installation date, to:

CertainTeed Gypsum
4300 W. Cypress St., Ste 500
Tampa, FL 33607
USA

Attn: Product Manager
GlasRoc Sheathing

To effect this sole and exclusive remedy, the claim must be submitted in writing prior to the end of the warranty period.

THIS SHALL CONSTITUTE THE TOTAL LIABILITY OF CERTAINTEED AND THE EXCLUSIVE REMEDY OF CUSTOMER. THERE ARE NO OTHER WARRANTIES, EXPRESS OR IMPLIED, INCLUDING ANY WARRANTY OF MERCHANTABILITY OR FITNESS FOR A PARTICULAR PURPOSE. LIABILITY IS LIMITED TO THE ABOVE AND CERTAINTEED SHALL IN NO EVENT BE LIABLE FOR LABOR CHARGES, INCLUDING BUT NOT LIMITED TO, LABOR CHARGES IN CONNECTION WITH REMOVAL OR REPLACEMENT, NOR FOR INCIDENTAL OR CONSEQUENTIAL DAMAGES.

No representative of CertainTeed has the authority to make any representation or promise with respect to this limited warranty or otherwise amend, restate, or supplement this limited warranty.

GlasRoc® Sheathing

Architectural Specifications

Section 09253 / 06 16 00 - Sheathing

Part 1-General

1.1 RELATED DOCUMENTS

- A. Drawings and general provisions of the Contract, including General and Supplementary Conditions and Division 1. Specification Sections, apply to this Section.

1.2 SUMMARY

- A. This Section includes the following:
1. Embedded Glass Reinforced Gypsum (EGRG™) Sheathing Board.
 2. Sheathing joint-and-penetration treatment.

1.3 DEFINITIONS

- A. Gypsum Board Construction Terminology Standard: Refer to ASTM C 11 for definitions of terms for gypsum sheathing board construction not defined in this Section or in other referenced standards.

1.4 SUBMITTALS

- A. Submit in accordance with Section 01330.
B. Product Data: For each type of product indicated.
C. Informational Submittals: Submit manufacturer's instructions, special procedures, and perimeter conditions requiring special attention.

1.5 QUALITY ASSURANCE

- A. Fire-Test-Response Characteristics: For assemblies with fire-resistance ratings, provide materials and construction identical to those of assemblies tested for fire resistance per ASTM E 119 (UL 263, CAN/ULC-S101) by a testing and inspecting agency acceptable to authorities having jurisdiction.
1. Fire-Resistance Ratings: Indicated by design designations from ULI and ULC "Fire Resistance Directory" and Products Certified for Canada.
- B. Single Source Responsibility: Except where specified otherwise, obtain gypsum board products, joint treatment, and accessories from single manufacturer or from manufacturers recommended by prime manufacturer of gypsum board products.

1.6 DELIVERY, STORAGE, AND HANDLING

- A. Store materials protected against damage from weather, direct sunlight, surface contamination, construction traffic, or other causes. Stack CertainTeed GlasRoc® Sheathing flat on leveled supports off the ground, under cover, and fully protected from weather.
1. Store and support CertainTeed GlasRoc® Sheathing board in flat stacks to prevent sagging.
 2. Protect materials to keep them dry.
 3. Protect gypsum board panels to prevent damage to edges, ends, and surfaces.

1.7 COORDINATION

- A. CertainTeed GlasRoc® Sheathing:
1. EGRG™ Sheathing Board: Intended for up to 12 (twelve) months of exposure following installation.

1.8 WARRANTY

- A. Manufacturer's standard warranty for product exposed to weather without failure, when installed in accordance with manufacturer's requirements, for period of not less than 12 months.

Part 2-Product

2.1 GYPSUM SHEATHING

- A. Fully embedded glass mat gypsum sheathing meeting the requirements of ASTM C 1177.
1. CertainTeed Gypsum, Inc.
 - a. Basis of Design: "GlasRoc® Sheathing" with EGRG™ technology
 - b. Substitutions: Submit in accordance with Section 01600.
 2. Type and Thickness: Type X, 5/8 inch (15.9 mm) thick where indicated and as otherwise required to meet fire rating for specific element. [1/2 inch (12.7 mm) elsewhere.]
 - a. Flame spread: ASTM E 84 (CAN/ULC-S102): 0 maximum.
 - b. Smoke developed: ASTM E 84 (CAN/ULC-S102): 0 maximum.
 3. Size: 48 by not less than 96 inches (1219 by not less than 2438 mm); longer lengths as available to reduce number of joints.

2.2 SHEATHING JOINT-AND-PENETRATION TREATMENT MATERIALS

- A. Silicone Emulsion Sealant: Meeting ASTM C 920, Type S, Grade NS, compatible with glass fiber mesh tape and for covering exposed fasteners.
B. Glass-Fiber Mesh Tape: Self-adhering glass-fiber tape, 2 inches (50 mm) wide, 10 by 10 or 10 by 20 threads/inch (390 by 390 or 390 by 780 threads/m), of type recommended by sheathing and tape manufacturers for use with silicone emulsion sealant in sealing joints in glass-mat gypsum sheathing board and with a history of successful in-service use.

2.3 ACCESSORY MATERIALS

- A. Fasteners: Steel drill screws or nails, in lengths recommended by sheathing manufacturer for thickness of sheathing board to be attached, with organic-polymer or other corrosion-protective coating. For ceiling/soffit applications with Direct-Applied Exterior Finish Systems (DEFS) and painted ceilings/soffits, fasteners having a salt spray resistance of more than 800 hours according to ASTM B 117 are recommended.
1. For steel framing less than 0.0329 inch (0.835 mm) thick, attach sheathing with steel drill screws complying with ASTM C 1002.
 2. For steel framing from 0.033 to 0.112 inch (0.84 to 2.84 mm) thick, attach sheathing with drill screws complying with ASTM C 954.
 3. For wood framing, attach with nails or screws of type and spacing as recommended by sheathing manufacturer

Part 3-Execution

3.1 GYPSUM SHEATHING INSTALLATION

- A. Comply with GA-253, ASTM C 1280 and manufacturer's written instructions.
B. Install CertainTeed GlasRoc® Sheathing with acrylic coated side (logo side) out. Boards are also printed with "Install This Side Out" on the face side.
C. Cut boards at penetrations, edges, and other obstructions of work; fit tightly against abutting construction, unless otherwise indicated.

1. Install boards with a 3/8-inch (10 mm) setback where non-load-bearing construction abuts structural elements.
 2. Install boards with a 1/4-inch (6 mm) setback where they abut masonry or similar materials that might retain moisture, to prevent wicking.
 3. Allow no joints greater than 1/8 inch (3 mm).
- D. Coordinate sheathing installation with flashing and joint-sealant installation so these materials are installed in sequence and manner that prevents exterior moisture from passing through completed exterior wall assembly.
- E. Apply fasteners so screw heads bear tightly against face of sheathing boards but do not cut into facing.
- F. Do not bridge building expansion joints with sheathing; cut and space edges to match spacing of structural support elements.
- G. Horizontal Installation: Install sheathing with long edges in contact with edges of adjacent boards without forcing. Abut ends of boards over centers of stud flanges, and stagger end joints of adjacent boards not less than one stud spacing. Screw-attach boards at perimeter and within field of board to each steel stud.
1. Space fasteners approximately 8 inches (200 mm) o.c. (or tighter spacing if recommended by manufacturer for specific application) and set back a minimum of 3/8 inch (10 mm) from edges and ends of boards.

3.2 SHEATHING JOINT-AND-PENETRATION TREATMENT

- A. Seal sheathing joints, as required, according to sheathing manufacturer's written recommendations.
1. If a weather seal is required before the application of a water-resistive barrier, apply silicone emulsion sealant on joints and trowel flat. Apply sufficient quantity of sealant to completely cover joints after troweling. Seal other penetrations and openings. Check with the water-resistive barrier manufacturer for installation instructions prior to the application of sealant.
 2. As an alternate to separate water-resistive barrier - Apply glass-fiber mesh tape to fiberglass reinforced gypsum sheathing board joints, and apply and trowel silicone emulsion sealant to embed sealant in entire face of tape. Apply sealant to exposed fasteners with a trowel so fasteners are completely covered. Seal other penetrations and openings.
- B. Water-Resistive Barrier:
1. Consult building code authority having jurisdiction for requirements regarding water-resistive barrier installation, if necessary.

3.3 Ceilings and Soffits

- A. Finishing is accomplished with one of the following methods:
1. Direct-Applied Exterior Finish System (DEFS) is applied per the manufacturer's specifications.
 2. Apply 2"x10x10 glass mesh drywall tape and 90 minute, setting-type joint compound on the board joints. Skim coat the entire surface with a setting-type compound, prime and paint with good quality exterior grade primer and paint per the manufacturer's recommendations.

SAFETY:

For more information, consult the Material Safety Data Sheet by contacting CertainTeed at 1-800-233-8990 or email: building.solutions@certainteed.com. For an electronic copy of this specification, please visit: www.certainteed.com

Great Design Deserves Great Protection.



GlasRoc® Sheathing featuring patented* Embedded Glass Reinforced Gypsum™ technology is strong, yet flexible enough to bend to curved surfaces like the towers at The Avenue at Westchase.

Project: The Avenue at Westchase
Project Type: Mixed-use Commercial Development
Location: Westchase Village, Tampa, FL
Application: Exterior Insulating Finishing System (EIFS)
Square Footage: 80,000 sq. ft.
Architect: Nathan Griffes, Cuhaci & Peterson Architects

* Covered by U.S. Patent No. 6,524,679; 6,878,321; 6,866,492, and other patents pending.

Cover Photo: Grove City Church of the Nazarene, Grove City, Ohio
Architect: McKnight and Hosterman Architects, Inc.
General Contractor: McKnight Development Company

ASK ABOUT OUR OTHER CERTAINTEED PRODUCTS AND SYSTEMS:

EXTERIOR: ROOFING • SIDING • WINDOWS • FENCE • RAILING • TRIM • DECKING • FOUNDATIONS • PIPE
INTERIOR: INSULATION • GYPSUM • CEILINGS

CertainTeed Corporation
P.O. Box 860
Valley Forge, PA 19482

Professional: 800-233-8990
Consumer: 800-782-8777
www.certainteed.com

CertainTeed 

Characteristics, properties or performance of materials or systems manufactured by CertainTeed herein described are derived from data obtained under controlled test conditions. CertainTeed makes no warranties, express or implied, as to their characteristics, properties or performance under any variations from such conditions in actual construction. CertainTeed assumes no responsibility for the effects of structural movement. CertainTeed and the tag line "Quality made certain. Satisfaction guaranteed." are trademarks of CertainTeed Corporation. All other trademarks are the property of its affiliates and related companies.

NOTICE: The information in this document is subject to change without notice. CertainTeed assumes no responsibility for any errors that may inadvertently appear in this document.

©01/08 CertainTeed Corporation. Printed in U.S.A. CTG-2355/15M/Rev 12-2008