

# ROLLING COUNTER DOORS



## Model ESC10

**Rolling Counter Doors** secure openings above counters and other similar finished openings on interior and exterior walls. Can fully close to the floor when compact door components are desired. Also called shutters.



**Sizes:** Standard construction for openings up to 21' wide or 10' high.

**Operation:** Motor, hand crank, or push-up designs available based on size and weight. Lifting the counter door requires no more than 25 lbs. of force.

**WHEN COMPACT DOOR COMPONENTS ARE DESIRED, COUNTER DOORS CLOSE TO THE FLOOR**

### COMPONENT FEATURES AND OPTIONS

Reference page 2 for Rolling Door Product construction overview.

#### CURTAIN

Interlocking 1 1/2" slats in rolled #18 B & S gauge or extruded .055" aluminum with clear or color anodized finish, 22 gauge galvanized steel with exclusive GalvaNex™ finish in light gray or 22 gauge stainless steel with #4 finish.

#### BOTTOM BAR

On aluminum or galvanized steel curtains, bottom bars are clear anodized extruded aluminum tubular sections with continuous lift handles. On stainless steel curtains, bottom bar is a stainless steel angle. Vinyl astragal standard on counter door bottom bars.

**Locking:** Standard coil side lockable slide bolts. Optional master-keyable cylinder locks operable from either or both sides of the curtain.

#### GUIDES

Two-piece extruded aluminum guide sections with clear anodized finish and polypropylene pile runners snap together, concealing fasteners. Or choose formed stainless steel sections.

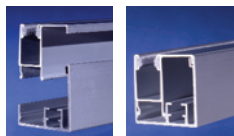

#### HOOD

Matching #18 B & S gauge clear anodized aluminum, 24 gauge galvanized steel with exclusive GalvaNex™ finish in light gray or 24 gauge #4 finish stainless steel. Additional finishes, mechanisms and motor covers available.

**Counter Door Options Include:**

#### FINISHES

**SPECTRASHIELD** Full spectrum of durable colors available with Cornell's in-house powder coating system. See pg 2.

#### COUNTERTOPS

Available in stainless steel or standard plastic laminates in a range of solid colors and other looks.

### ADDITIONAL COUNTER DOOR OFFERINGS

#### GRAPHICS DOOR

Add durable, full-color images to your curtains and hoods. Great for school logos and turning unused door space into profitable sponsorship opportunities in stadiums, amusement parks and retail stores. For photo, see page 17 and also page 13.

### SCREENGARD™ Perforated Counter Door Slat

Achieve visibility and ventilation while maintaining security and insect control. Perforated 22 gauge galvanized steel slat provides approximately 22% open space.



### DETAILS AND CLEARANCES

#### CLEARANCES

Coil sizes range from 8" to 14" depending on unit size, material and operation. Please consult factory whenever coil size is critical.

#### SECTION

#### ELEVATION

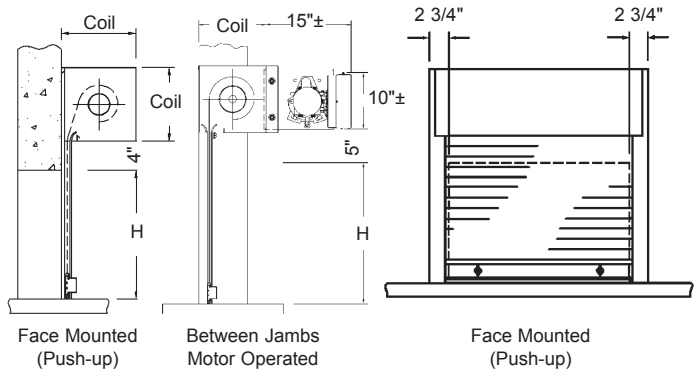

#### BOTTOM BAR DETAILS

#### FLAT SLAT SECTION #1F

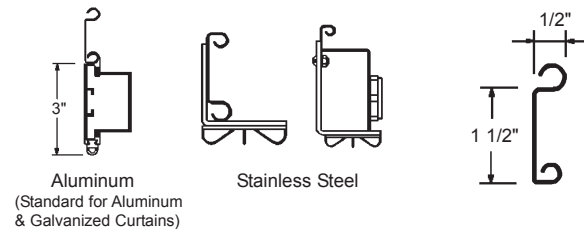

#### JAMB DETAILS

#### ALUMINUM (STANDARD FOR ALL CURTAIN MATERIALS)

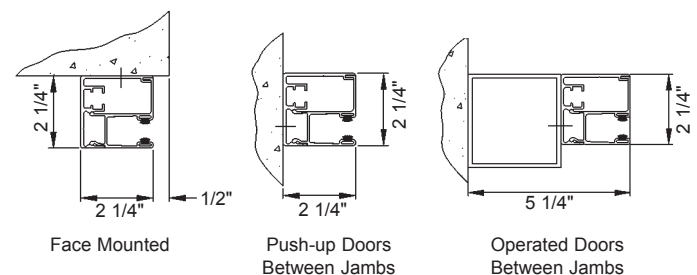

#### STAINLESS STEEL (OPTIONAL FOR ALL CURTAIN MATERIALS)

