

ROLLING GRILLES

SENTRYGATE®3 Model ESG20, SENTRYGATE®4 Model ESG21

SentryGate®, a patented* Cornell product, is an alternative to traditional rolling grilles or counter grilles featuring a unique curtain comprised of injection molded components and continuous metal rods.

Available in two configurations:

- **SentryGate3:** Model ESG20 - for countertops such as pharmacies and parts counters and smaller openings up to 14' W by 10' H.
- **SentryGate4:** Model ESG21 - for larger openings up to 23' 4" W x 14' H and where high cycling is required.



Operation: Motor, hand crank, or push-up designs are available. Operation requires no more than 25 lbs. of force.

SentryGate Benefits:

- **Quick Security Fix:** A lightweight and compact design allows the unit to bolt directly to existing wall construction, frames or mullions. Units can be easily incorporated into existing construction without the penalty of remodel downtime and cost.
- **Rugged Curtain Construction:** SentryGate curtains will maintain structural integrity and a clean look, even with high cycle use.

SentryGate Options Include:

- **High Cycle Construction:** High cycle shaft and springs available. Consult factory with cycle requirements.

COMPONENT FEATURES AND OPTIONS

Reference page 2 for Rolling Door Product construction overview.

CURTAIN

Combines high strength injection molded components with continuous metal rods spaced every two inches. Its attractive brick pattern design is 65% open for high visibility and ventilation. The smooth curtain components are safe for employees and customers, and are available in black or white matte finish.



BOTTOM BAR

The SentryGate3 bottom bar is an extruded aluminum tubular section with a continuous lift handle, clear or color anodized, equipped with a vinyl astragal/weather seal to cushion the contact point on the counter. Locking is by coil-side slide bolts or master-keyable cylinder lock operable from either or both sides of the gate. The SentryGate4 bottom bar is a 2" x 3 1/2" heavy-duty aluminum tubular section in mill, clear or color anodized finish that houses optional locking mechanisms.

GUIDES

SentryGate3 guides are box style, heavy-duty aluminum sections, clear or color anodized, with a polypropylene pile runner and a curtain retaining bar. Guides are attached to jambs with 1/4" bolts at maximum 12" intervals. 2-piece aluminum guide sections snap together, concealing fasteners. Bracket plates slip-in and tighten in place. SentryGate4 guides are heavy-duty extruded aluminum sections, mill finish, clear or color anodized, equipped with polypropylene pile runners that are supported with structural support tubes or wall mounting angles.

HOOD

Optional-and usually omitted when curtain stores recessed-hoods are available in 24 gauge galvanized steel with exclusive GalvaNex™ finish in light gray, 24 gauge 300 series stainless steel with a #4 finish, or aluminum in mill, clear or color anodized finish. Additional finishes, mechanism and motor covers available.

*SentryGate® is a patented product of Cornell Iron Works, US Patent No. 6,189,593

DETAILS AND CLEARANCES

CLEARANCES

SentryGates may require less head room clearance than traditional grilles. Coil size ranges from 7" to 15" depending on unit size, operation and cycle requirements. Please consult factory whenever coil size is critical.

SentryGate demo available on video. Please call for a free copy or view now at www.cornelliron.com



SECTION

ELEVATION

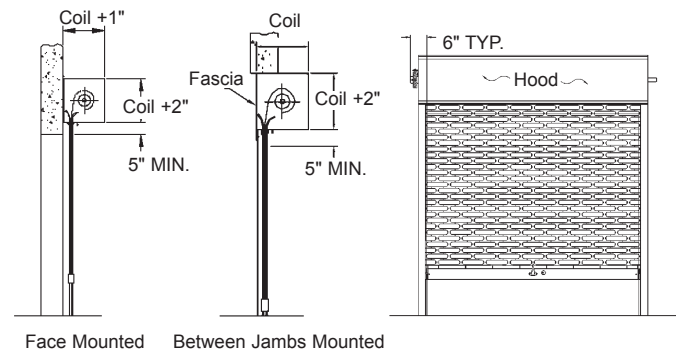

JAMB DETAILS

SENTRYGATE3

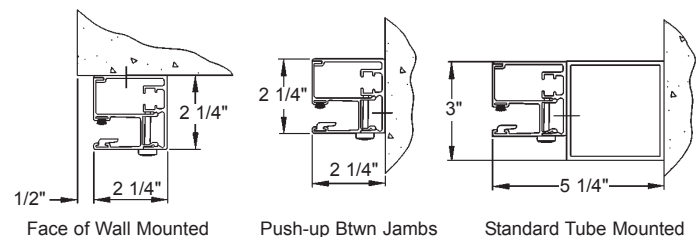

SENTRYGATE4

