

REZNOR®

Model UEAS



Super High Efficiency Separated Combustion, Low Static Unit Heaters for Commercial/ Industrial Use



DESCRIPTION

Reznor® V3 Series Model UEAS gas-fired, high efficiency, separated combustion unit heaters are available in 4 sizes ranging from 131,000 to 305,000 BTUH gas input. Heaters are designed for up to 93% thermal efficiency and are approved for installation in the United States and Canada by ETL.

Reznor® V3 Series unit heaters have a refreshing appearance with a glossy white cabinet finish and less visible hardware. Each size cabinet is easily suspended from 4 suspension points. The low voltage terminal strip on the outside of the cabinet makes connecting control wiring easy with no panels to remove. The addition of a "G" terminal to the low voltage strip, along with the new design of the circuit board, allows for fan only operation (without adding relays). All units have a factory installed gas line nipple to the exterior of the cabinet for easy gas service connection. The MacroChannelSM secondary heat exchanger has a 1/2" PVC pipe for attaching a coupling for ease of installation and cleaning of the required condensate drain. A 4" PVC cleanout cap that is drilled and tapped for a 1/2" NPT fitting is furnished with the heater for attaching the vent condensate drain.

The preeminent new internal feature is the TCORE³TM high efficiency heat exchanger and single burner combustion system. Other standard features include a single-stage gas valve, multi-try direct spark ignition with 100% lockout, pressure switch to verify vent flow, venter motor, aluminum venter wheel with housing, resiliently isolated axial fan and motor assembly, a high temperature limit control, interlock door switch, and a built-in disconnect switch. Operation is controlled through an integrated circuit board. The circuit board monitors heater operation and has LED diagnostic indicator lights to identify abnormalities in control functions.

The 1ST ever separated combustion system in the commercial/industrial heating industry **was introduced on a Reznor heater** in the 1960s, and that proven technology is continued in this new separated combustion product. Model UEAS separated combustion units require installation of a specially designed combustion air/vent system including the unique concentric adapter box that allows for only one building penetration for both the vent and combustion air.

The V3 Series unit heaters are designed to provide all the features you expect in a Reznor heater plus improved efficiency, easier installation, and a new look ~ **both inside and out**. Look for the unique white unit with no visible front and bottom hardware, deep red louvers, black side handle, and angled corner to know you have a genuine Reznor unit by Thomas & Betts.

STANDARD FEATURES

- Up to 93% Thermal efficient ~ **Most efficient unit heater in the world!**
- 50-60°F temperature rise range
- Arranged for use with natural gas (propane conversion kit included with unit)
- **NEW** TCORE³TM titanium stabilized aluminized steel primary heat exchanger with extruded aluminum MacroChannelSM secondary heat exchanger (patent pending)
- **NEW** patented ⁴ TCORE³TM single burner combustion system including a one-piece burner assembly
- 115/1/60 Supply voltage
- 115 Volt open fan motor with internal overload protection
- Transformer for 24-volt controls
- Integrated circuit board with diagnostic indicator lights
- Multi-try direct ignition with 100% lockout
- Fan relay (included on the circuit board)
- Single-stage natural gas valve (field adjustable for operation to 10,000 ft. [3,000 meters] elevation)
- Vibration/noise isolated fan motor
- Sealed control compartment houses all electrical components
- 48 frame, ball bearing, PSC venter motor
- 4-point Suspension
- Built-in disconnect switch (20A @ 115V Rating)
- External terminal strip for 24-volt wiring
- Sealed junction box for supply wiring
- External gas connection
- Fully gasketed door panel with safety door switch
- Full fan guard ~ **engineered for safety**
- Improved cabinet design with less visible hardware and a **NEW** Reznor appearance

OPTIONAL FEATURES - FACTORY INSTALLED

- 409 stainless steel primary heat exchanger
- Totally enclosed fan motor (115 V only)

NOTE: Model UEAS should not be used in applications where space temperature is set below 45°F.

ACCESSORIES - FIELD INSTALLED

- *Horizontal or vertical combustion air/vent kit including concentric adapter
 - Thermostat
 - Thermostat guard with locking cover
 - Vertical louvers
 - Downturn nozzle kits
 - Manual shutoff valves
- * Selection of either a horizontal or vertical combustion air/vent kit is required.
 ** U.S. Patent No. 6,889,686

TECHNICAL DATA

Model UEAS

MODEL NUMBER		130	180	260	310
INPUT HEATING CAPACITY	BTUH	131,000	175,000	260,000	305,000
	KW/H	38.4	51.2	76.1	89.3
THERMAL EFFICIENCY		93%	91%	92%	91%
OUTPUT HEATING CAPACITY ^A	BTUH	121,830	159,250	239,200	277,550
	KW/H	35.7	46.6	70.0	81.3
GAS CONNECTION (INCHES) ^B	NATURAL	1/2	1/2	3/4	3/4
	PROPANE	1/2	1/2	3/4	3/4
VENT CONNECTION DIAMETER (INCHES)		4	4	4	4
COMBUSTION AIR INLET DIAMETER (INCHES)		6	6	6	6
CONTROL AMPS (24 - VOLT)		1.0	1.0	1.0	1.0
FULL-LOAD AMPS (115V)		6.3	6.3	10	10
MAXIMUM OVER CURRENT PROTECTION (115V) ^C		15	15	20	20
NORMAL POWER CONSUMPTION (WATTS)		657	657	1020	1020
DISCHARGE AIR TEMPERATURE RISE (°F.)		50	60	50	60
AIR VOLUME	CFM	2256	2458	4430	4283
	M ³ /MINUTE	63.9	69.6	125.4	121.3
DISCHARGE AIR OPENING AREA (FT. ²)		2.56	2.56	4.79	4.79
OUTLET VELOCITY (FPM)	FPM	883	962	924	894
	M/MINUTE	269	293	282	272
FAN MOTOR HP ^D	STANDARD	1/4	1/4	1/2	1/2
	OPTIONAL ENCLOSED	1/4	1/4	1/2	1/2
FAN MOTOR RPM		1050	1050	1050	1050
FAN DIAMETER (IN.)		18	18	24	24
APPROXIMATE CONDENSATE PER HOUR	Gallons	1	1	2	2
	Liters	3.8	3.8	7.6	7.6
APPROXIMATE NET WEIGHT	LBS	230	245	360	395
	KG	104	111	163	179
APPROXIMATE SHIP WEIGHT	LBS	255	270	385	420
	KG	116	122	175	190

^A FOR ALTITUDES TO 2000 FEET.

^B SIZES SHOWN ARE FOR GAS CONNECTION TO A SINGLE-STAGE GAS VALVE, NOT GAS SUPPLY LINE SIZE.

^C MODP = 2.25 X (LARGEST MOTOR FLA) + SMALLEST MOTOR FLA. ANSWER IS ROUNDED TO THE NEAREST COMMERCIALLY AVAILABLE CIRCUIT BREAKER.

^D ALL OTHER INFORMATION IN THIS TABLE IS BASED ON A HEATER EQUIPPED WITH A STANDARD 115 VOLT OPEN FAN MOTOR.

HOW IT WORKS

Following is a diagram showing the air flow patterns for Model UEAS. Thin arrows show air flow from combustion air intake, across the burner, through primary and secondary heat exchangers and out exhaust vent. Larger arrows show air flow across the heat exchanger to provide heat to the space.

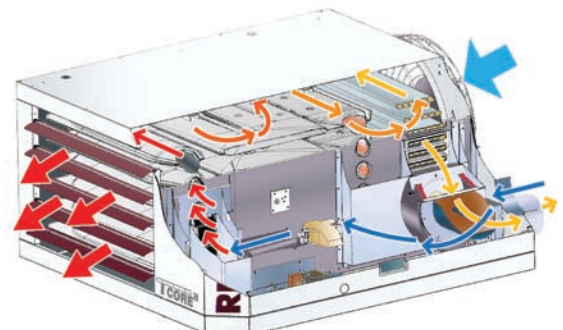

DIMENSIONS

Model UEAS

±1/16" (2mm)

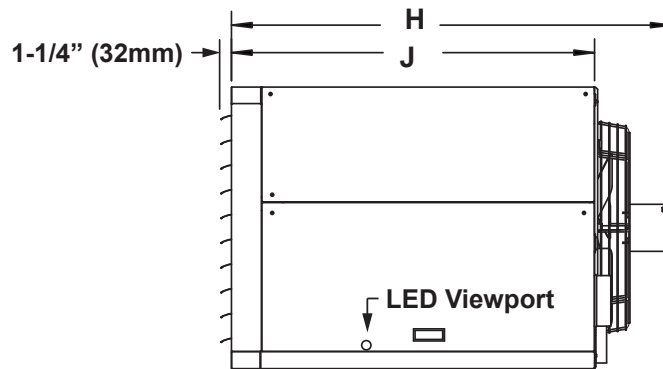
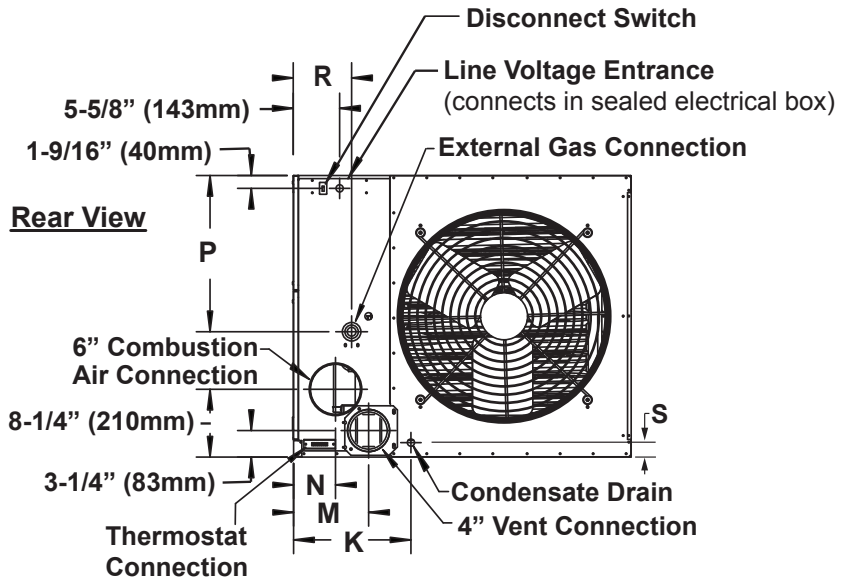
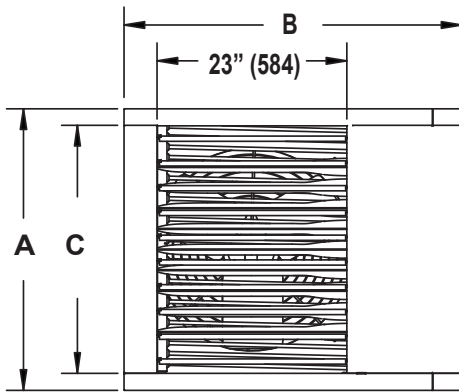
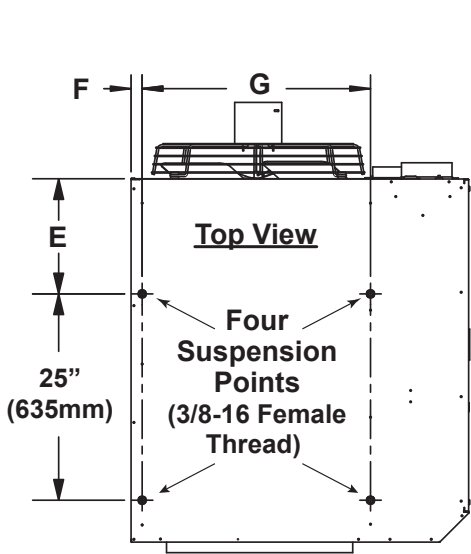

Size	A	B	C	E	F	G	H	J	K	M	N	P	R	S
Dimensions - inches (±1/8 inch)														
130, 180	20 1/8	39 3/16	16 1/16	11 15/16	2 3/8	25 11/16	50 1/2	42	13 7/16	8 5/16	4 5/16	5 1/16	6 5/16	1 3/4
260, 310	34 1/8	40 15/16	30 1/16	13 15/16	1 3/8	27 11/16	53 5/16	44	14 7/32	9 3/32	5 1/16	18 15/16	7 3/4	1 3/8
Dimensions - mm (±3 mm)														
130, 180	(511)	(995)	(408)	(303)	(60)	(652)	(1,283)	(1,067)	(341)	(211)	(110)	(129)	(160)	(44)
260, 310	(867)	(1,040)	(764)	(354)	(35)	(703)	(1,354)	(1,118)	(361)	(231)	(129)	(481)	(197)	(35)