

Innovative double lap design increases holdown stiffness and fastener shear values. Reduces eccentricity in the studs/post decreased centerline dimension. No thru-bolts to countersink.

- Materials:** 12 gauge
Finish: G90 galvanizing
Codes: SBCCI, BOCA – NER 564, FL817,
 L.A. City RR 25434

Installation:

- Use all specified fasteners. See Product Notes, page 16.
- **Place the PHD over the anchor bolt. No washer is required.**
- Install with USP’s code evaluated WS3 (1/4” x 3”) Wood Screws, which are provided with the holdown.
- Tighten anchor bolt nuts finger tight snug to base, plus 1/3 to 1/2 additional turns with a wrench. To prevent loosening of the anchor nut during critical loading, use a locking nut or tighten a second nut over the first to lock nuts in place.
- **PHD Predeflected Holdowns may be installed off sill plate with no load reduction.**
- The design engineer may specify any alternate anchorage calculated to resist the tension load for a specific application. Anchorage exposure length should take the bearing plate height of 1 5/8” into account, anchor bolt thread should visibly extend above nut.
- If used to anchor a built-up post, such as a double 2 x 4, the post component shall be designed to act as a single unit. Holddown fasteners specified shall not be considered to attach multiple plys together.
- For anchorage options see STBL Anchor Bolt section on pages 34-35.

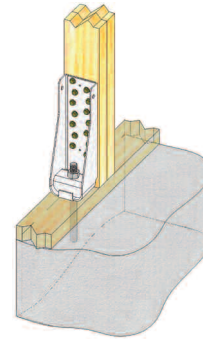

Typical PHD5 installation

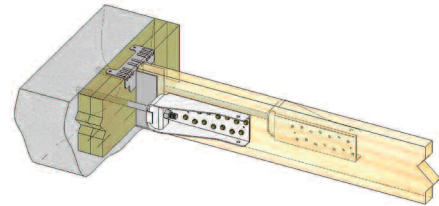

Typical PHD5 concrete wall offset installation

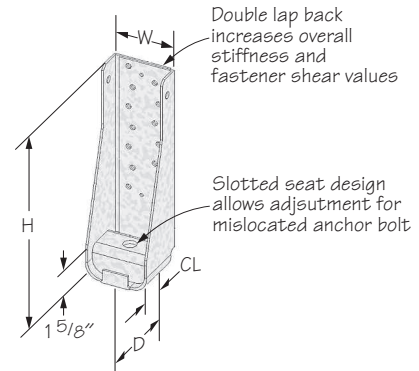

PHD5

USP Stock No.	Ref. No.	Steel Gauge	Dimensions				Fastener Schedule		Allowable Loads (Lbs.) ^{1,2,5,8}		Deflection at 133% Allowable Design Load ^{4,6}
			W	H	D	CL	Anchor Bolts ³	Wood Screws ⁷	DF-L / SP		
									133%	160%	
PHD2	PHD2-SDS3	12	3-1/4	7-1/2	3	1-3/8	(1) 5/8	(10) WS3	4230	4770	0.039
PHD5	PHD5-SDS3	12	3-1/4	10-7/8	3	1-3/8	(1) 5/8	(14) WS3	5920	6125	0.049
PHD6	PHD6-SDS3	12	3-1/4	13-1/16	3	1-3/8	(1) 7/8	(18) WS3	7155	7155	0.048
PHD8	PHD8-SDS3	12	3-1/4	16-1/2	3	1-3/8	(1) 7/8	(24) WS3	8295	8295	0.054

1) Allowable loads are based on the 1997 NDS®.
 2) Allowable loads have been increased 33-1/3% or 60% for wind and seismic loads; no further increase shall be permitted.
 3) The designer must specify anchor bolt type, length, and embedment.
 4) Deflections are derived from static, monotonic load tests of devices connected to DF-L wood members with specified fasteners.
 5) The designer shall consider the effect of compression, bearing, tension, and combined bending due to device eccentricity when applicable.
 6) The PHD may be elevated off the sill.
 7) WS3 wood screws are 1/4” x 3” and are included with PHD models.
 8) Minimum post thickness is 3”. Consult USP for installations less than 3”.