

Aluminum floor access covers for flexible floor finishes

Features

- Visedge Series covers are suitable for all types of flexible sheet flooring, e.g. PVC or linoleum.
- The PVC extrusion is locked to the frame sections, and bonded and welded to the cut edge of the sheet flooring, forming an impermeable, flat, hygienic and permanent joint.
- The aluminum and steel construction is tough, light and non-rusting.
- Crimped corners allow the cover and frame to lie completely flat.
- The unique Howe Green double seal construction forms the most positive seal to drainage, electrical and other ducts.
- Any size is available (between maximum and minimum sizes) for single covers or duct layouts.

General notes on Visedge series floor access covers

Size – All covers are made to measure using the Howe Green patented system. This allows the manufacture of any size between the stated maximum and minimum dimensions. Sizes that may be thought 'non-standard' can therefore be obtained without delay and without cost surcharge. The versatile nature of the Howe Green system allows any configuration of ducts and branches to be created.

Weight – The weight of the access cover should be taken into account where ease of handling is an important consideration. In all cases reference should be made to the relevant manual handling regulations. If loads are excessive, consideration should be given to the use of hydraulic lifters, or our HSE 75 range.

Where large covers are necessary, over pits containing plant for example, the main covers can be fitted with small inset covers to allow easy access for routine maintenance. The main covers need then only be removed for major overhauls or plant replacement.

Visedge Series Aluminum Single Cover

floor access covers for pedestrian traffic

Typical floor finishes

Vinyl, linoleum, rubber, all flexible floor coverings and some carpets.

Performance

Light duty suitable for pedestrian traffic (including wheeled trolleys and sack trucks) only.

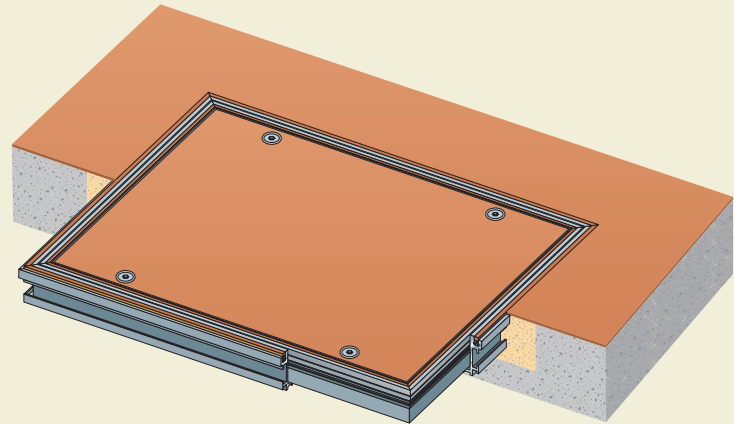

Cross section showing concrete and timber sub-floors (Scale 1:2)

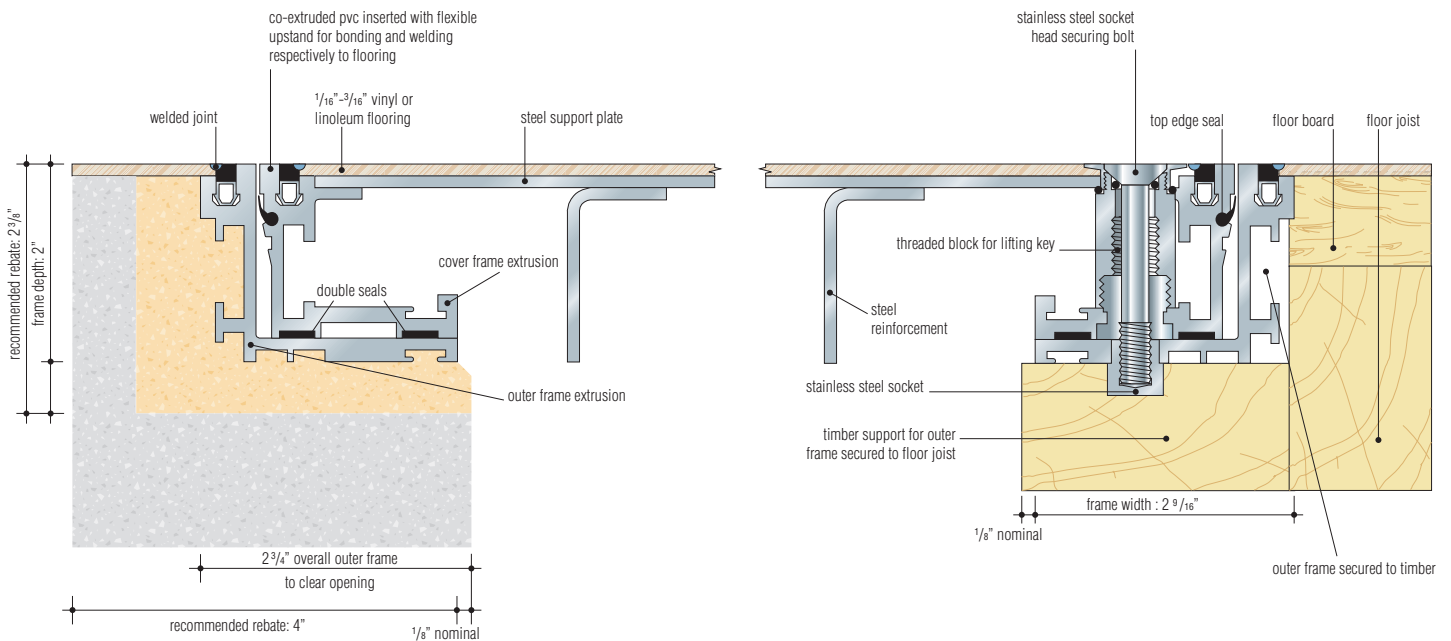

Typical specification clause for Visedge series

Aluminum access covers and duct/multipart covers* and frames shall be Howe Green Ltd Visedge series with top edge dirt seal, weldable pvc securing edge, mechanically jointed corners, double sealed on seating and fitted with securing bolts. Sizes shall be as shown on contract drawings nos† Covers are to be supplied complete with† sets of combined lifting/securing keys. All to be manufactured and supplied by Howe Green Ltd, www.howegreen.com and installed in accordance with the manufacturer's installation details and site work guide.

* Delete as appropriate. † Insert appropriate numbers and quantities

Size

Overall frame size = clear opening + $5\frac{3}{8}$ " e.g. 24" x 24" clear opening = $29\frac{3}{8}$ " x $29\frac{3}{8}$ " overall frame width. Subject to correct installation (see separate installation guide). See also general notes on cover.

Weight

A Visedge series cover weighs approx. 11lb/ft².

Maximum / minimum sizes

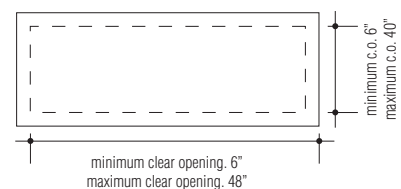

Visedge Series Aluminum Duct Cover

floor access covers for pedestrian traffic

Typical floor finishes

Vinyl, linoleum, rubber, all flexible floor coverings and some carpets.

Performance

Light duty suitable for pedestrian traffic (including wheeled trolleys and sack trucks) only. Consult the Howe Green Technical Department for heavier loadings.

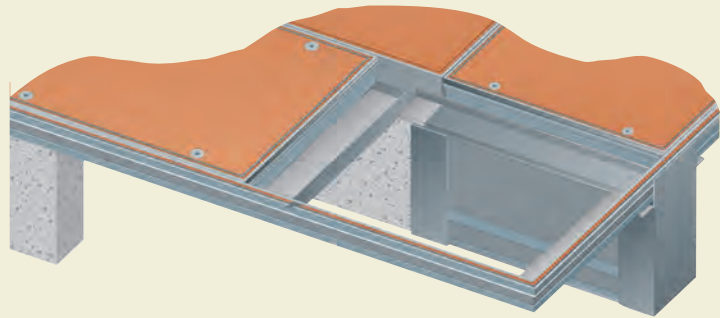

Cross section showing anchor lug and locking/lifting detail (scale 1:2)

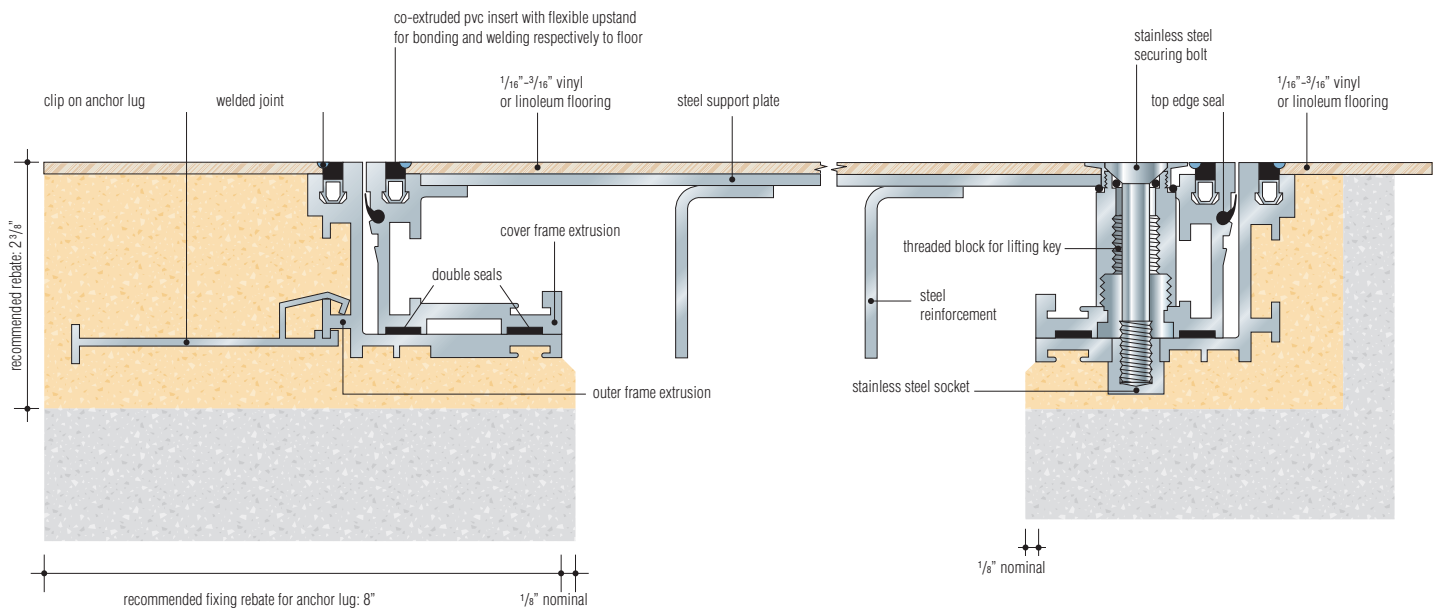

Size

Overall frame size = clear opening + $5\frac{3}{8}$ " e.g. 24" clear opening = $29\frac{3}{8}$ " overall frame. Subject to correct installation (see separate installation guide). See also general notes on cover.

Weight

A Visedge series cover weighs approx. 11lb/ft².

Typical Layout

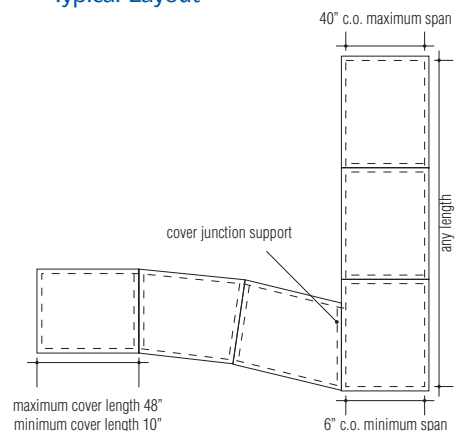

Visedge Series Aluminum Multipart Cover

floor access covers for pedestrian traffic

Typical floor finishes

Vinyl, linoleum, rubber, all flexible floor coverings and some carpets.

Performance

Light duty suitable for pedestrian traffic (including wheeled trolleys and sack trucks) only. Consult the Howe Green Technical Department for heavier loadings.

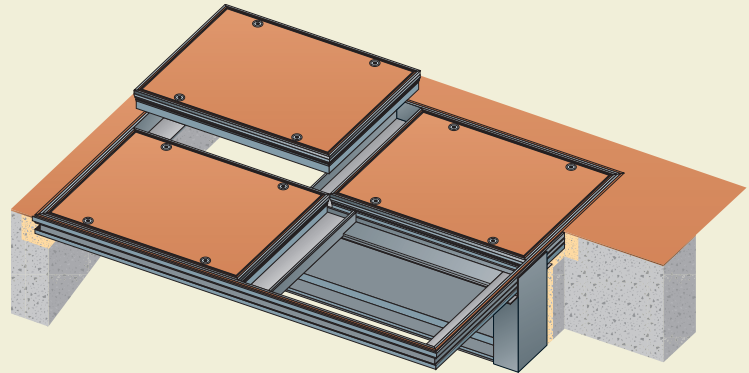

Cross section showing removable support beam and cross members (Scale 1:2)

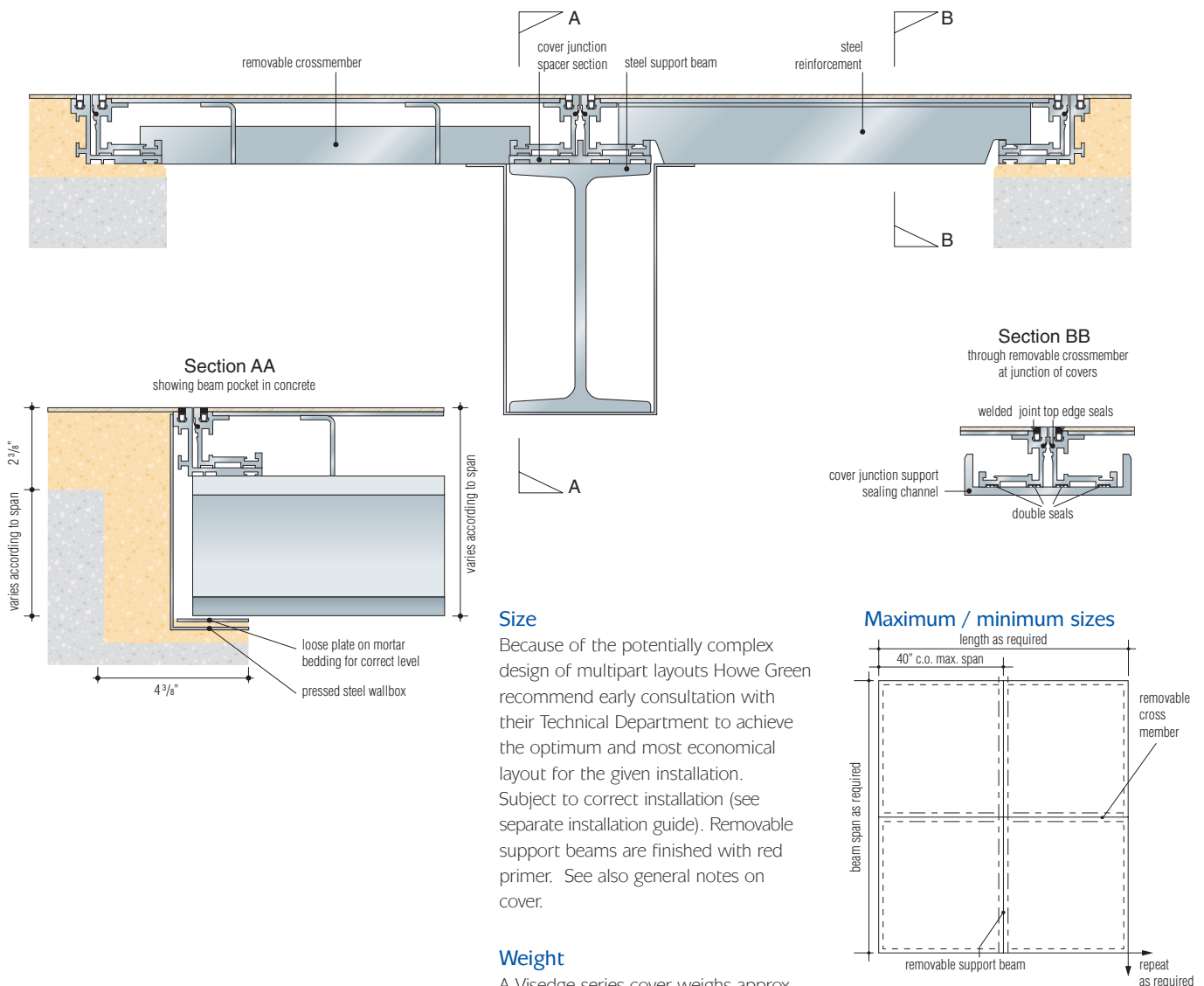

Size

Because of the potentially complex design of multipart layouts Howe Green recommend early consultation with their Technical Department to achieve the optimum and most economical layout for the given installation. Subject to correct installation (see separate installation guide). Removable support beams are finished with red primer. See also general notes on cover.

Weight

A Visedge series cover weighs approx. 111lb/ft².